

FEATURES

- Two-Circuit Double-Break Limit Switches
- Rigid die cast switch housing. Made up of zinc alloy and reinforced plastic.
- Small sized, oil-tight, waterproof
- Inbuilt with a micro switch with double read structure for longer mechanical service life
- Larger Over Travel operations
- Catheter design for easy wiring
- Many types of actuator. Easy to use.

SPECIFICATIONS

RATINGS

Rated Voltage (V)	Non-inductive load (A)				Inductive load (A)			
	Resistive Load		Lamp Load		Inductive Load		Motor Load	
	NC	NO	NC	NO	NC	NO	NC	NO
125VAC	5	5	1.5	0.7	3	3	2	1
250VAC	5	5	1	0.5	3	3	1.5	0.8
8 VDC	5	5	3	3	5	4	3	3
14 VDC	5	5	3	3	4	4	3	3
30 VDC	5	5	3	3	4	4	3	3
125 VDC	0.4	0.4						
250 VDC	0.2	0.2						
Inrush Current	N.C.:24A max. N.O.:12A max.							

- Notes: 1. Inductive load: power factor = 0.4 (AC);
time constant = 7 msec (DC)
2. Lamp load has an inrush current of 10 times the steady-state current while motor load has an inrush current of 6 times the steady-state current.

OPERATING CHARACTERISTICS

Type	TZ-1104	TZ-1108	TZ-1107	TZ-1111	TZ-1112 TZ-1122	TZ-1166 TZ-1167 TZ-1168 TZ-1169
OF max.	750g	750g	750g	900g	900g	150g
RF min.	100g	100g	100g	150g	150g	—
PT max.	20°	20°	20°	1.5mm	1.5mm	30mm
OT min.	50°	50°	50°	4mm	4mm	—
MD max	12°	12°	12°	1mm	1mm	—
OP	—	—	—	26±0.8mm	37±0.8mm	—

CONTACT CONFIGURATION

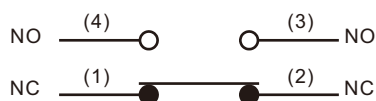

CHARACTERISTICS

Operating Speed	0.5mm to 50cm/s
Operating Frequency	Mechanically:120 operations/min Electrically:30 operations/min
Contact Resistance	25mΩ (max.)(initial)
Insulation Resistance	100MΩ max. (at 500VDC)
Dielectric Strength	1,000 VAC, 50/60 Hz, for 1 minute between non-continuous terminals; 1,500 VAC, 50/60 Hz, for 1 minute between non-current-carrying metal part and between each terminal and ground.
Vibration	10 to 55HZ, 1.5mm double amplitude
Shock	Mechanical durability: approx. 1,000m/S ² (approx. 100G'S) Malfunction durability: approx. 500m/S ² (approx. 30G'S)
Ambient Temperature	Operating: -5 to +65°C
Humidity	95%RH max.
Service Life	Mechanically: 10,000,000 operations min. Electrically: 500,000 operations min.
Weight	Approx. 130 to 190g
Degree of Protection	IEC:IP65

TZ-1104

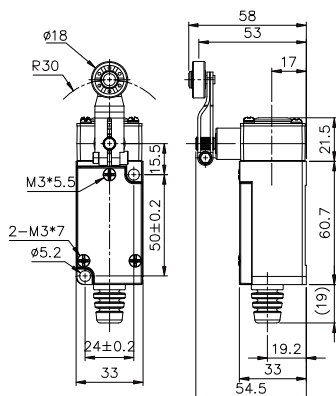

TZ-1108

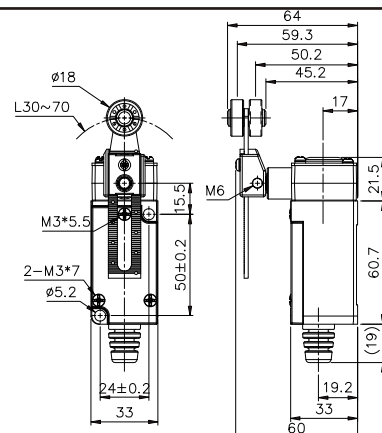

TZ-1107

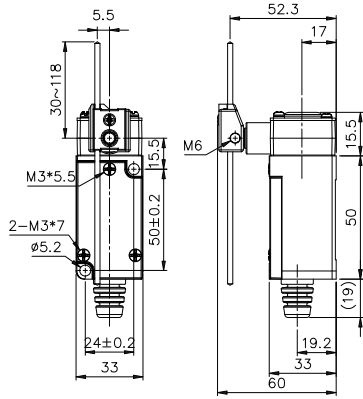

TZ-1112

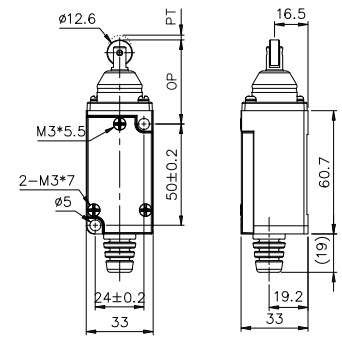

TZ-1111

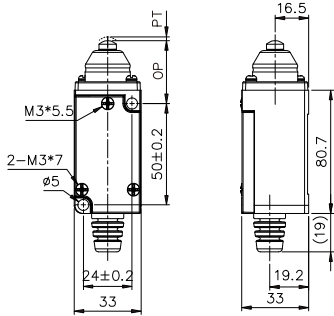

TZ-1122

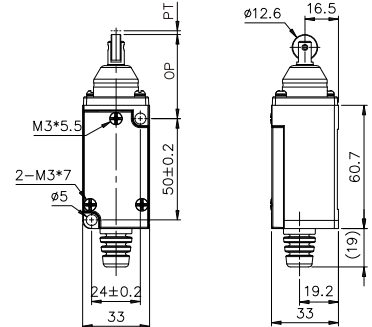

TZ-1166

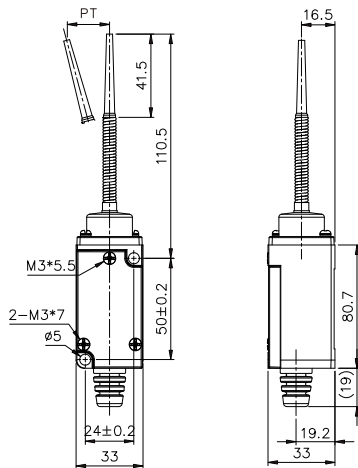

TZ-1167

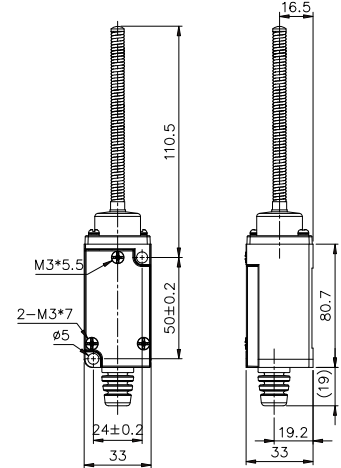

TZ-1168

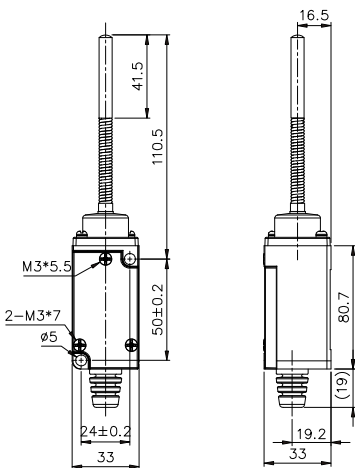

TZ-1169

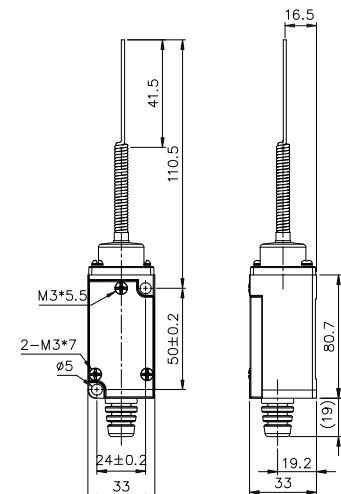

SPECIFICATIONS

RATINGS

Rated Voltage (V)	Non-inductive load(A)				Inductive load (A)				Inrush Current (A)	
	Resistive Load		Lamp Load		Inductive load		Motor Load			
	NC	NO	NC	NO	NC	NO	NC	NO	NC	NO
125 VAC	5		1.5		3		2		1	
250 VAC	5		1.5		3		1		0.5	
8 VDC	5		-		1.5		-		10 max. 10 max.	
14 VDC	5		-		1.5		-			
30 VDC	5		-		1.5		-			
125 VDC	0.5		-		0.05		-			
250 VDC	0.25		-		0.03		-			

CHARACTERISTICS

Operating Speed	0.01mm to 1m/sec(Plunger Type)
Operating Frequency	Mechanically: 240 operations/min Electrically: 20 operations/min
Contact Resistance	15mΩ max. (initial)
Insulation Resistance	100MΩ min. (at 500VDC)
Dielectric Strength	1,000 VAC, 50/60Hz, for 1 minute between non-continuous terminals; 1,500 VAC, 50/60 Hz, for 1 minute between current-carrying metal part and ground.
Vibration	(*10~20HZ): 1.5mm double amplitude Malfunction durability: 10~55Hz
Shock	Mechanically durability: 1,000m/Sec ² (approx. 100G'S) Malfunction durability: 300m/Sec ² (approx. 30G'S)
Ambient Temperature	-10°C ~ +80°C (Not freezing)
Humidity	Max. 95%RH
Service Life	Mechanically: 10,000,000 operations min. Electrically: 500,000 operations min.
Weight	About 22 to 58g
Degree of Protection	Sealed: (IEC) IP67

OPERATING CHARACTERISTICS

Type	TZ-2311	TZ-2312
OF max.	1200g	1200g
RF min.	500g	500g
PT max.	1.5mm	1.5mm
OT min.	3mm	3mm
MD max.	(0.1mm)	(0.1mm)
OP	0.8±0.8	31.4±0.8

CONTACT CONFIGURATION



DEFINITIONS OF OPERATING CHARACTERISTICS

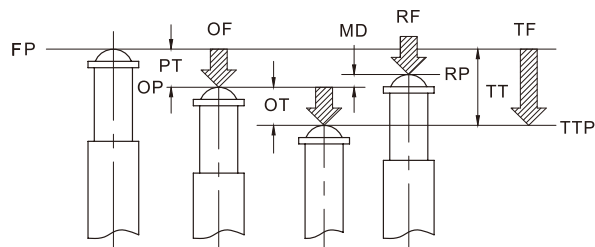

Operate

Release

OF: Operating Force

TTP: Total Travel Position

RF: Releasing Force

PT: Pre Travel

TF: Total Force

OT: Over Travel

FP: Free Position

MD: Movement Differential

OP: Operating Position

TT: Total Travel

RP: Releasing Position

APPEARANCE and DIMENSIONS

TZ-2311

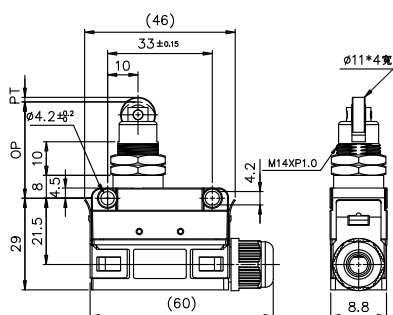

TZ-2312

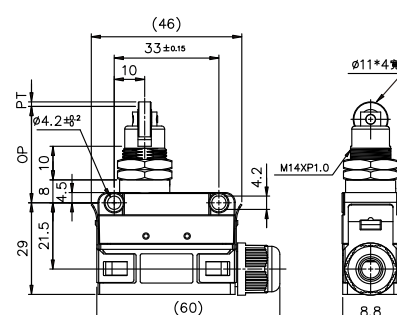



SPECIFICATIONS

- DPDS limit switch for multiple applications.
- Rugged aluminum alloy diecast housing.
- High mechanical strength.
- Oil resistance, waterproof and dust proof structure.

RATINGS

Rated Voltage (V)	Non-inductive load(A)				Inductive load(A)			
	Resistive load		Lamp load		Inductive load		Motor load	
	NC	NO	NC	NO	NC	NO	NC	NO
125VAC	5 (0.1)		1.5	0.7	3		2.5	1.3
250VAC	3		1	0.5	2		1.5	0.8
8VDC	5 (0.1)		2		5	4	3	
14VDC	5 (0.1)		2		4	4	3	
30VDC	4 (0.1)		2		3	3	3	
125VDC	0.4		0.05		0.4		0.05	
250VDC	0.2		0.03		0.2		0.03	

OPERATION CHARACTERISTICS

Type	TZ-3101	TZ-3102	TZ-3103	TZ-3104	TZ-3110
OF Max.	1,200gf(11.77N)	1,200gf(11.77N)	1,200gf(11.77N)	580gf(5.69N)	1,200gf(11.77N)
RF Min.	450gf(4.41N)	450gf(4.41N)	450gf(4.41N)	150gf(1.47N)	450gf(4.41N)
PT Max.	1.8mm	1.8mm	1.8mm	25°	1.8mm
OT Min.	3mm	3mm	3mm	40°	3mm
MD Max.	0.2mm	0.2mm	0.2mm	3°	0.2mm
OP	15.7±1mm	28.5±1mm	28.5±1mm	—	28.5±1mm

Type	TZ-3111	TZ-3112	TZ-3113	TZ-3166	TZ-3169
OF Max.	1,800gf(17.65N)	1,800gf(17.65N)	1,800gf(17.65N)	150gf(1.47N)	150gf(1.47N)
RF Min.	450gf(4.41N)	450gf(4.41N)	450gf(4.41N)	—	—
PT Max.	1.8mm	1.8mm	1.8mm	15°	15°
OT Min.	3mm	3mm	3mm	—	—
MD Max.	0.2mm	0.2mm	0.2mm	—	—
OP	24.9±1mm	34.3±1mm	34.3±1mm	—	—

DIMENSIONS

TZ-3101

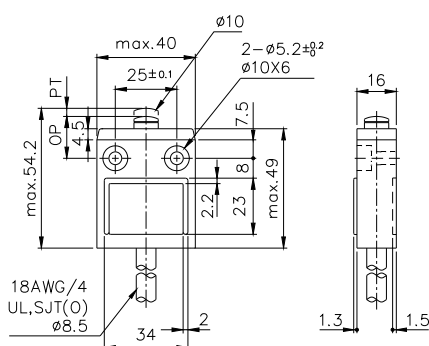

TZ-3102

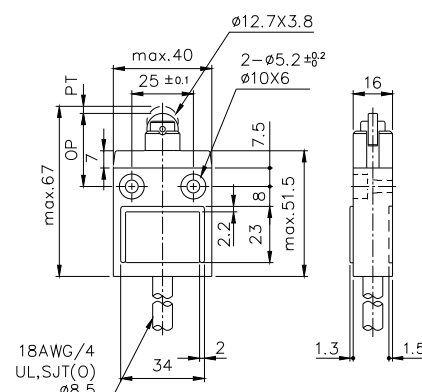

DIMENSIONS

TZ-3103

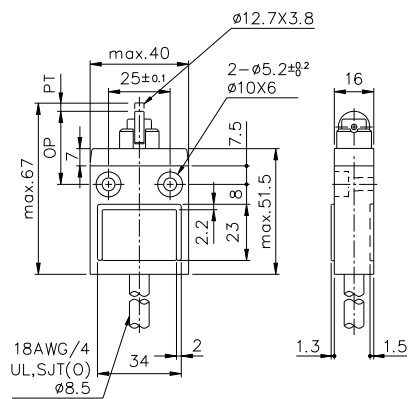

TZ-3110

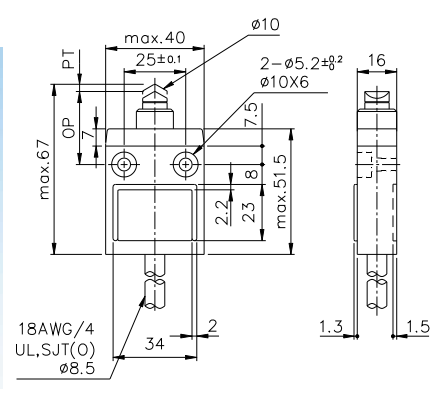

TZ-3111

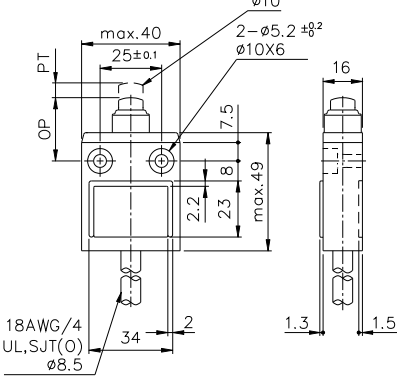

TZ-3112

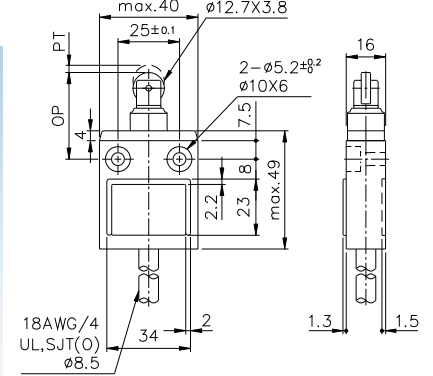

TZ-3113

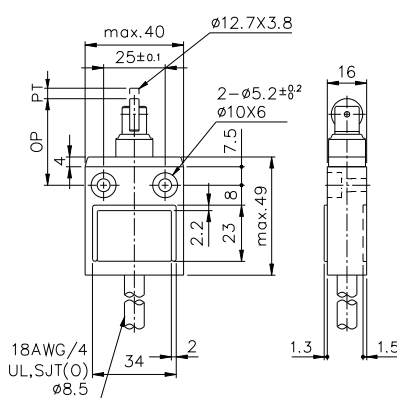

TZ-3104

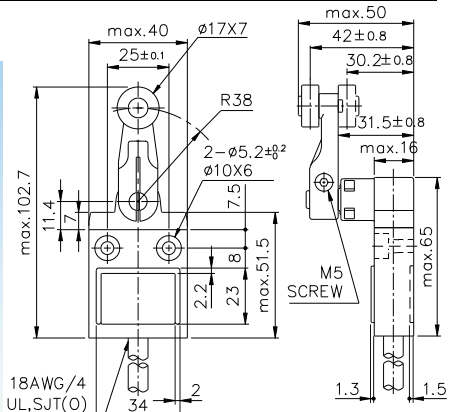

TZ-3166

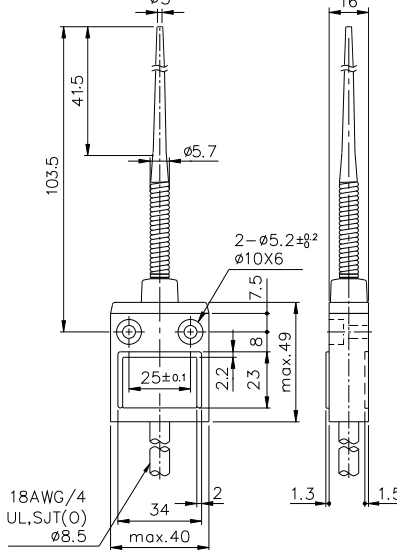

TZ-3169

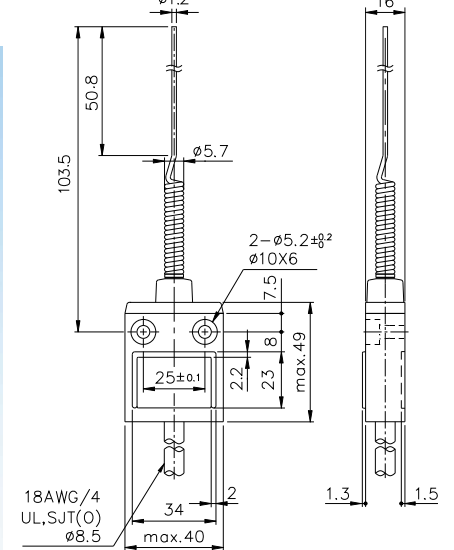

FASTENING OF THE SWITCH CABLE

The switch bodies are filled with resin for sealing purposes. To avoid stressing the cable and switch body, fasten the cable at 5cm or farther away from the switch body, should the wire be bent, the bending radius shall be least 45mm.

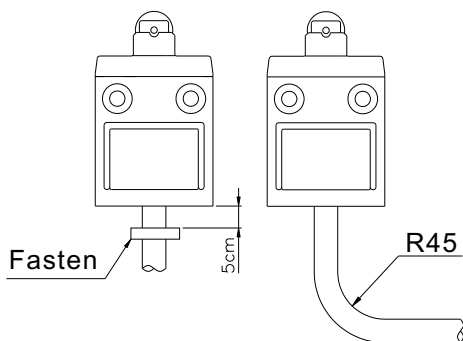

SWITCH BANK MOUNTING

A maximum of six switches may be mounted together as a switch bank. During the installation, the convex part of the switch back. The mounting panel shall be 6mm or thicker.

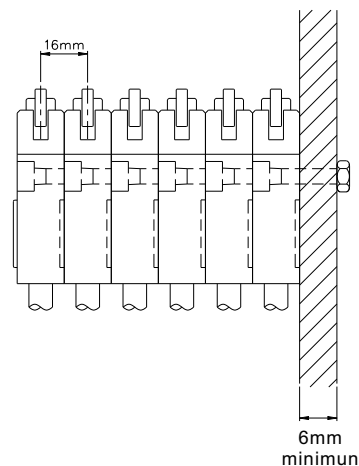

INSTALLATION

The service life and accuracy of switches will be effected by the shape of actuator operation frequency & over travel. So the angular of the fixing level should be about 30°, the surface finish of the fixing level should be over $\nabla\nabla\nabla$, the hard hardness is from hv400~500. When installing, the position of the concave part should be above the standard panel.

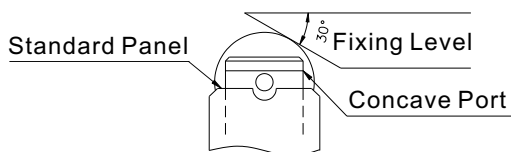

MOUNTING

Reccmended tightening torque according to the following form.

Model	Screw Type	Torque
1	M5 fastening screws	4.9~5.88N.m (50~60kgf.cm)
2	M3.5 installing screws	0.78~0.88N.m (8~9kgf.cm)

CONTACT TYPES

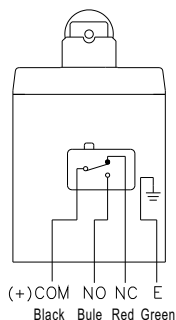

MOUNTING HOLES

mount the switch body to a rigid mounting panel using two m5 screws.

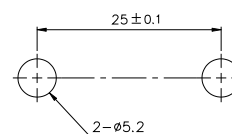

Wide Selection of Two-circuit Double-break Limit Switches



FEATURES

- Rigid diecast switch housing
- Set position indicator plate for easy maintenance
- High mechanical strength
- Oiltight, waterproof and dust-proof construction

SPECIFICATIONS

RATINGS

Rated Voltage (V)	Non-inductive load(A)				Inductive load(A)			
	Resistive load		Lamp load		Inductive load		Motor load	
	NC	NO	NC	NO	NC	NO	NC	NO
125VAC	10	10	3	1.5	10	5	3	2
250VAC	5	5	2	1	5	3	1.0	
480VAC	3	3	1.5	0.8	3	1.5	0.8	
600VAC	1	1	1	0.5	1.5	1	0.5	
8 VDC	10	6	3		10	6		
14 VDC	10	6	3		10	6		
30 VDC	6	4	3		6	4		
125 VDC	0.8	0.2	0.2		0.8	0.2		
250 VDC	0.4	0.1	0.1		0.4	0.1		

Notes: 1. Inductive load: power factor=0.4; time constant=7msec.
 2. Lamp load has an inrush current of 10 times the steady-state current while motor load has an inrush current of 6 times the steady-state current.

CONTACT CONFIGURATION

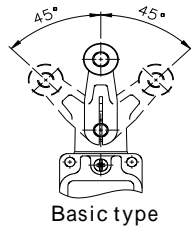
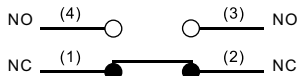

OVERTRAVEL TYPE

The Overtravel Type is a limit switch which is provided with a greater OT to facilitate dog setting. Since this type is identical to the Basic Type in dimensions, both types are interchangeable. The Overtravel Type is classified into two versions -2 series and -2N series.

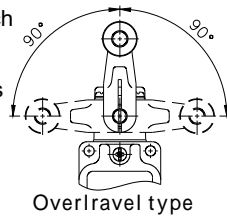

-2 SERIES

The head of -2 series switch can be installed in any of the four directions.
 90° operation on only one side - impossible
 90° operation on either side - possible

-2N SERIES

The head of -2N series switch can be installed only in two directions, forward and backward.
 90° operation on only one side - possible
 90° operation on either side - possible



Loosen the cam holder with a coin or screw driver → Reverse the cam → Reverse the position of the cam and reinstall

CHARACTERISTICS

Operating speed	1mm to 2m/sec (TZ5104)
Operating frequency	Mechanically: 120 operations/min Electrically: 30 operations/min
Contact resistance	15m max. (initial)
Insulation resistance	100M max. (at 500 VDC)
Dielectric strength	1,000 VAC, 50/60Hz, for 1 minute between non-continuous terminals; 2,200 VAC, 50/60Hz, for 1 minute between each terminal and non-current-carrying metal part and between each terminal and ground
Vibration	Malfunction durability: 10 to 55HZ, 1.5mm double amplitude
Shock	Mechanical durability: approx. 1,000m/sec ² (approx. 100G's) Malfunction durability: approx 300m/sec ² (approx. 30G's)
Ambient temperature	Operating: -10~+80°C
Humidity	95%RH max.
Service life	Mechanically: 15,000,000 operations min. Electrically: 500,000 operations min.
Weight	Approx. 275g (with Type TZ-5104)
Degree of protection	IEC: IP67
Temperature rise	50 degrees max.

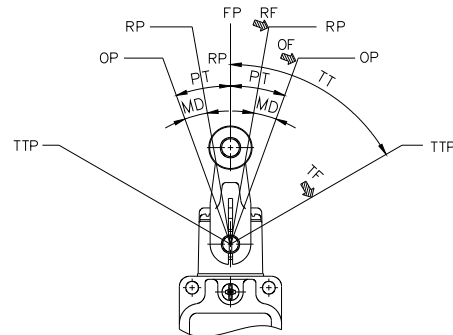

- OF: Operating Force
- RF: Releasing Force
- TF: Total Force
- FP: Free Position
- OP: Operating Position
- RP: Releasing Position
- TTP: Total Travel Position
- PT: Pretravel
- OT: Overtravel
- MD: Movement Differential
- TT: Total travel

90° operation on one side is possible by simply changing the direction of the cam.

Relationship of cam to operation as observed from the rear of switch

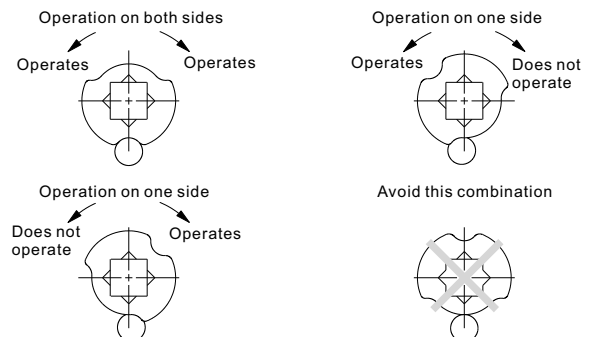

OPERATING CHARACTERISTICS

Type	TZ-5101	TZ-5102	TZ-5109	TZ-5104	TZ-5108	TZ-5107	TZ-5105
OF max.	2,720g	2,720g	2,720g	1,360g	1,360g	142g	1,200g
RF min.	910g	910g	910g	227g	227g	28g	-
PT max.	1.7mm	1.7mm	1.7mm	20°	20°	20°	55°
OT min.	6.4mm	5.6mm	4mm	30°	30°	30°	35°
MD max.	1mm	1mm	1mm	12°	12°	12°	-
OP	34±0.8mm	44.8±0.8mm	44.5±0.8mm	-	-	-	90±10°
TTP max.	29.5mm	39.5mm	41mm	-	-	-	-

Type	TZ-5106.5166.5168.5169	TZ-5104-2.5108-2	TZ-5107-2	TZ-5104-2N.5108-2N	TZ-5107-2N
OF max.	150g	1000g	290g	980g	290g
RF min.	-	100g	25g	120g	25g
PT max.	28mm	20°	20°	20°	20°
OT min.	-	55°	55°	70°	70°
MD max.	-	12°	12°	10°	10°

Mounting holes Basic type and -2 SERIES

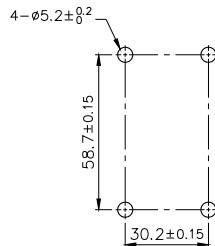

-2N SERIES

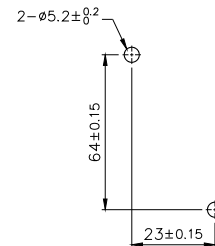
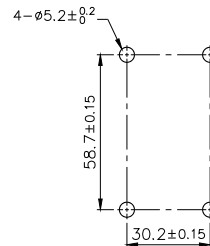

DIMENSIONS

TZ-5101

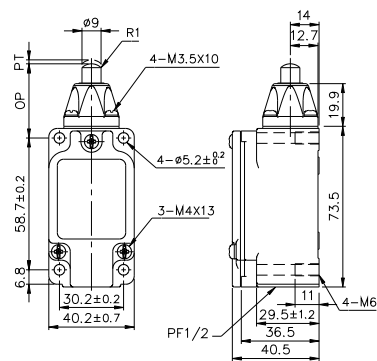

TZ-5102

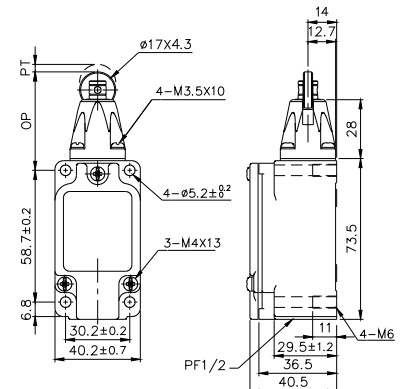

TZ-5103

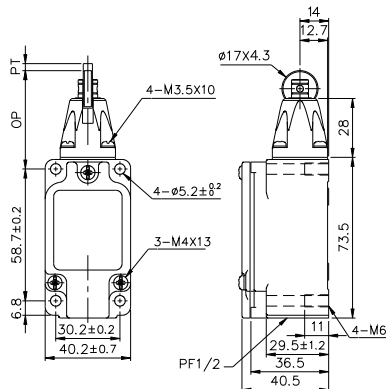

TZ-5105

TZ-5125 TZ-5135

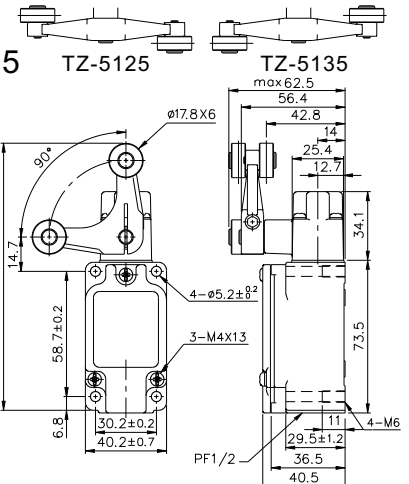

TZ-5104
TZ-5104-2

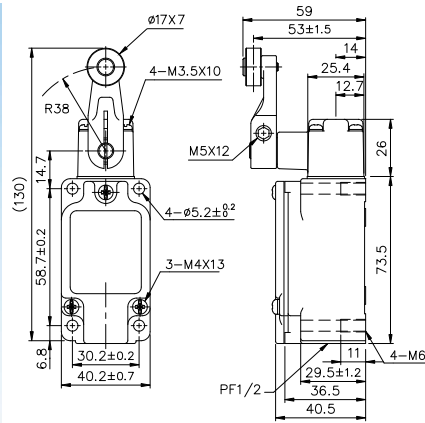

TZ-5104-2N

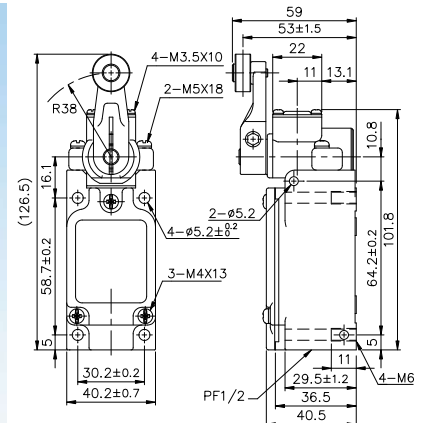

TZ-5107
TZ-5107-2

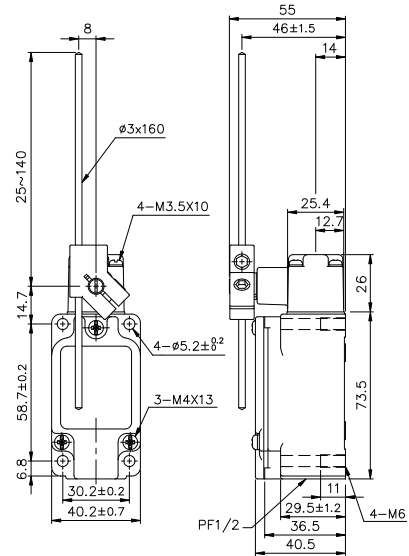

TZ-5107-2N

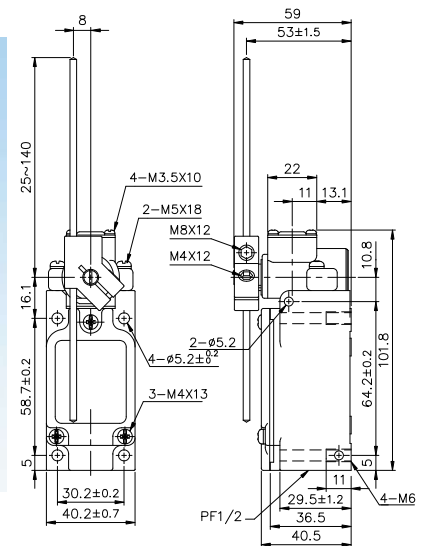

TZ-5108
TZ-5108-2

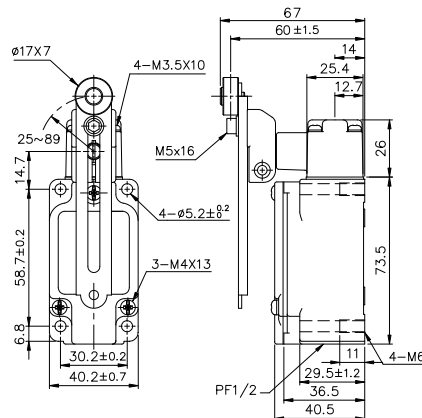

TZ-5108-2N

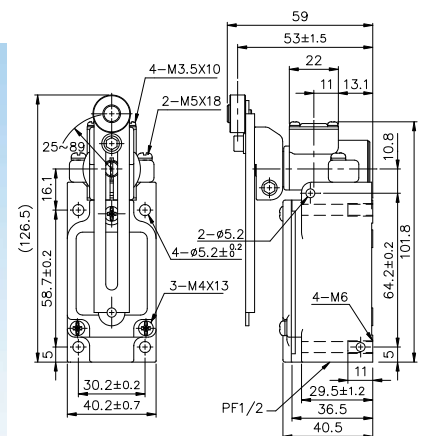

TZ-5106

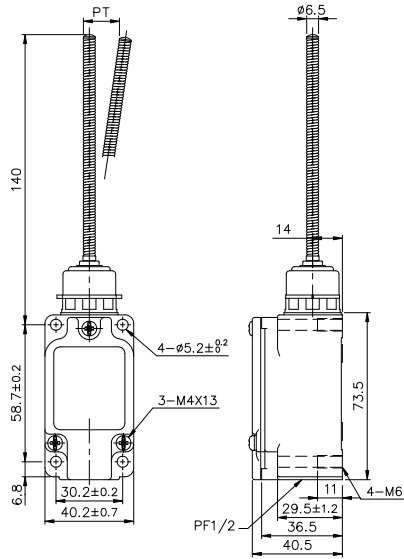

TZ-5109

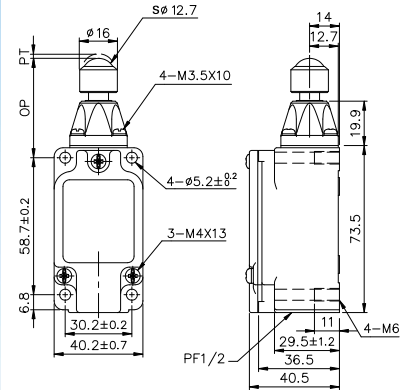

TZ-5166

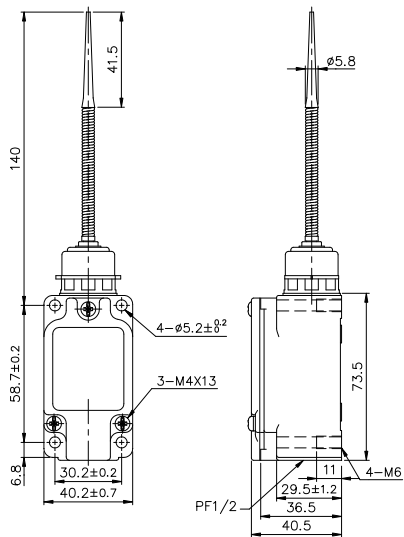

TZ-5168

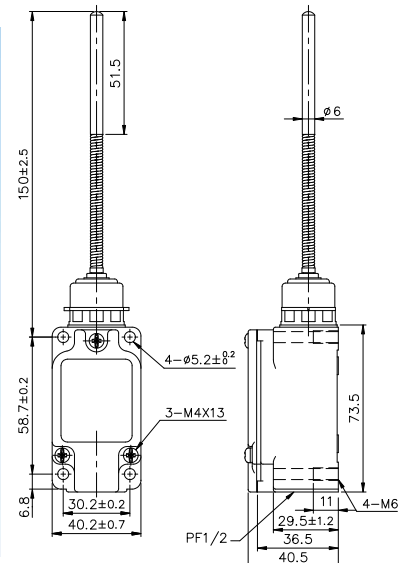

TZ-5169

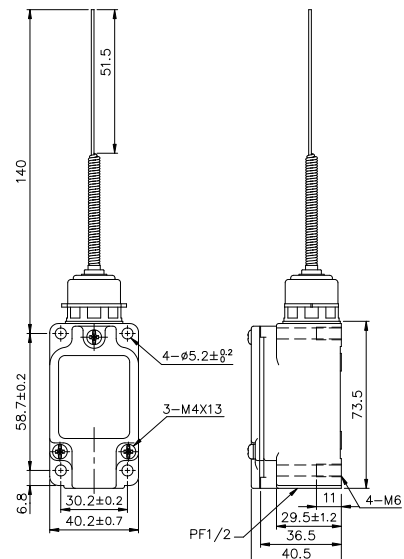

TZ-501

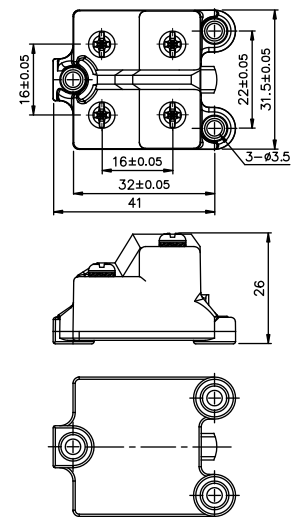

tend ENCLOSED SWITCH

TZ-6

Long Service Life and Large Breaking Capacity



A009142

FEATURES

- Models TZ-6 incorporate Model TM Micro Switches with rugged die cast cases.
- Available with various types of built-in switches (including split contact type ,maintained operation type , magnetic blowout type) and various actuators.
- Degree of Protection: IEC IP 65

SPECIFICATIONS

- CHARACTERISTICS
THE SAME AS MICRO SWITCH
SEE P. TB 1
- CONTACT CONFIGURATION

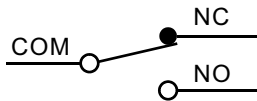

OPERATING CHARACTERISTICS

Type	TZ-6001	TZ-6002	TZ-6003	TZ-6004	TZ-6043
OF max.	350g	350g		570g	570g
RF min.	114g	114g		170g	170g
PT max.	0.4mm	0.5mm		4mm	4mm
OT min.	5.5mm	3.6mm		6mm	6mm
MD max.	0.05mm	0.05mm		0.4mm	0.4mm
OP	38.2±0.8mm	49.7±1mm			

Type	TZ-6101	TZ-6102	TZ-6103	TZ-6104	TZ-6143
OF max.	800g	500g		640g	640g
RF min.	240g	100g		230g	230g
PT max.	2mm	1mm		5mm	5mm
OT min.	5mm	3.5mm		6mm	6mm
MD max.	0.1mm	0.12mm		0.4mm	0.4mm
OP	45.8±0.8mm	49.7±0.8mm			

DIMENSIONS

TZ-6004

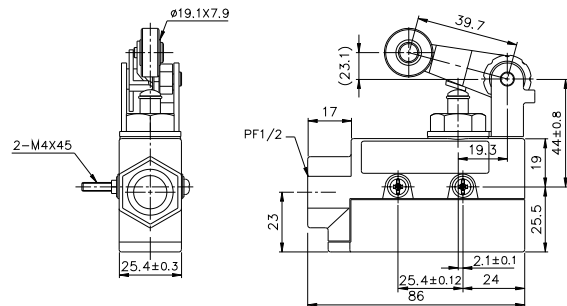

TZ-6104

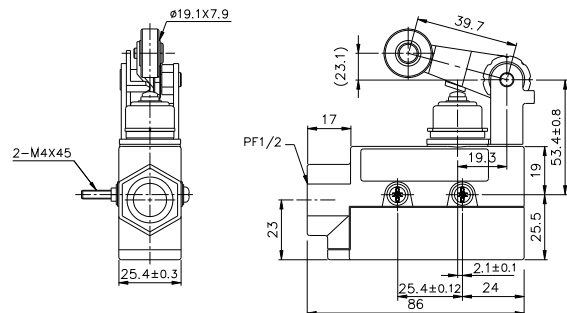

TZ-6143

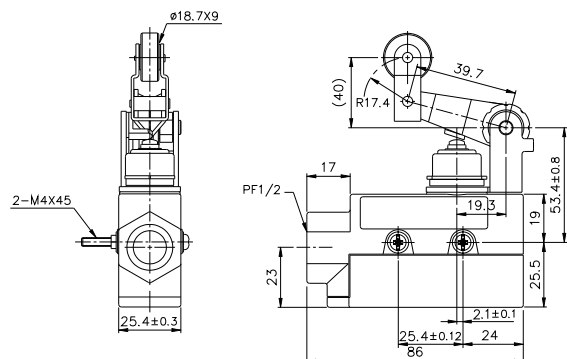

TZ-6001

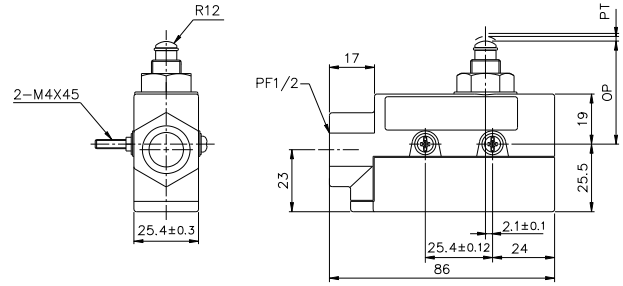

TZ-6002

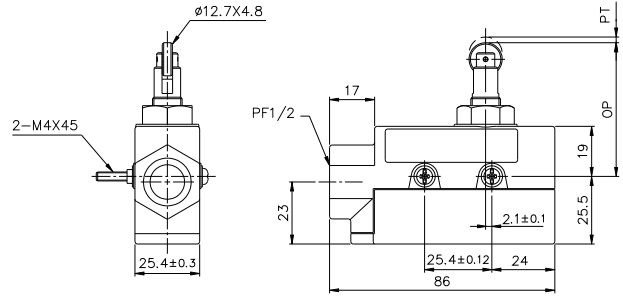

TZ-6101

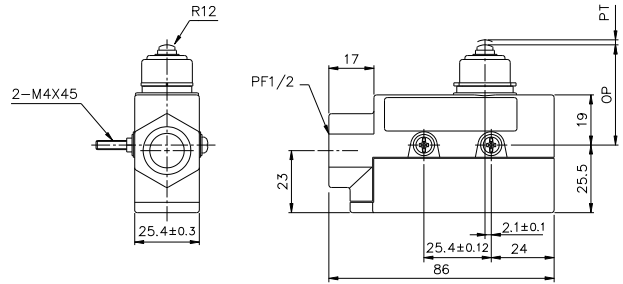

TZ-6102

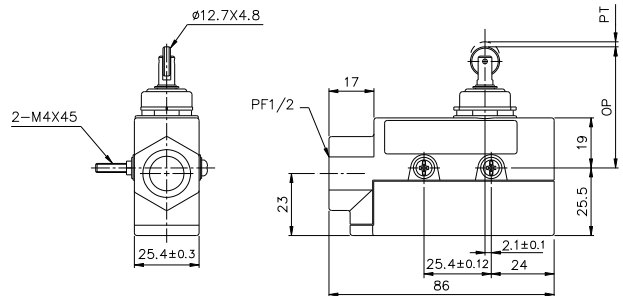

TZ-6043

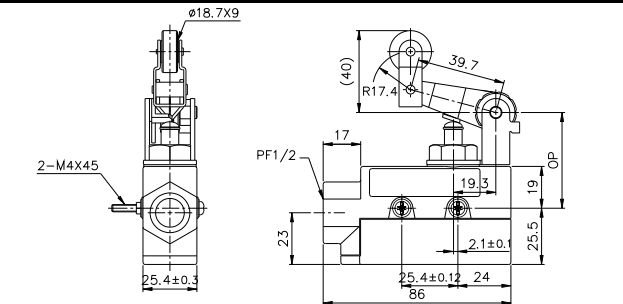

TZ-6106

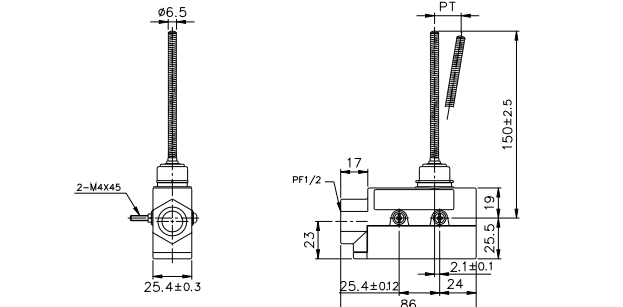

SPECIFICATIONS

- high precision and long life (10,000,000 mechanical operations)
- Sealed with gasket diaphragm to provide high sealing property without use of any adhesive or pin



A009142

SPECIFICATIONS

RATINGS

Rated Voltage (V)	Non-inductive load(A)				Inductive load(A)			
	Resistive load		Lamp load		Inductive load		Motor load	
	NC	NO	NC	NO	NC	NO	NC	NO
125VAC	10		3	1.5	10		5	2.5
250VAC	10		2.5	1.25	10		3	1.5
480VAC	3		1.5	0.75	2.5		1.5	0.75
8 VDC	10		3	1.5	6		6	5
14 VDC	10		3	1.5	6		6	5
30 VDC	8		3	1.5	6		5	2.5
125 VDC	0.5		0.4		0.05		0.05	
250 VDC	0.25		0.2		0.03		0.03	

Notes: 1. inductive load: power factor=0.4; time constant =7msec.

2. lamp load has an inrush current of 10 time the steady-state current while motor load has an inrush current of 6 times the steady-state current.

CONTACT CONFIGURATION

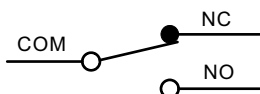

CHARACTERISTICS

Operating speed	0.01mm to 50cm/sec (at pin plunger)
Operating frequency	120 operations/min
Contact resistance	15m max. (initial)
Insulation resistance	100M max. (at 500 VDC)
Dielectric strength	1,000VAC,50/60Hz, fo 1minute between non-continuous terminals 1,500VAC,50/60Hz, for 1 1minute between current-carrying and non-current-carrying pasts and between each terminal and ground
Vibration	Mechanical durability: 10 to 55HZ,1.5mm double amplitude
Shock	Mechanical durability: 1,000m/S ² (approx. 100G's) malfunction: 300m/S ² (approx. 30G's)
Ambient temperature	Operating:- 10 to +80°C
Humidity	95% HR max. (at+20 to +35°C)
Service life	Mechanically: 10,000,000 operations min. (At rated ot value) Electrically: 500,000 operations min
weight	Approx. 60g
Degree of protection	IEC : IP65

OPERATION CHARACTERISTICS

Type	TZ-7100	TZ-7110	TZ-7310	TZ-7311	TZ-7312	TZ-7120	TZ-7140	TZ-7121	TZ-7141	TZ-7124	TZ-7144	TZ-7166
OF Max.	600g	600g	600g	600g	600g	150g	220g	180g	240g	200g	280g	120g
RF Min.	100g	100g	100g	100g	100g	40g	60g	50g	80g	60g	100g	
PT Max.	2.0mm	2.0mm	2.0mm	2.0mm	2.0mm	13.5mm	8.5mm	11.0mm	6.5mm	11mm	6.5mm	25mm
OT Min.	0.8mm	5.0mm	6.0mm	6.0mm	6.0mm	4.0mm	2.5mm	3.0mm	2.0mm	3.0mm	2.0mm	11mm
MD Max.	0.8mm	0.8mm	0.8mm	0.8mm	0.8mm	3.2mm	2.0mm	2.4mm	1.5mm	2.4mm	1.5mm	
OP	30.8±0.8mm	44±1.2mm	21.8±1.2mm	33.3±1.2mm		25±1mm	25±1mm	40±1mm	40±1mm	50±1.2mm	50±1.2mm	
FP						35mm	35mm		46mm		56mm	

DIMENSIONS

TZ-7121

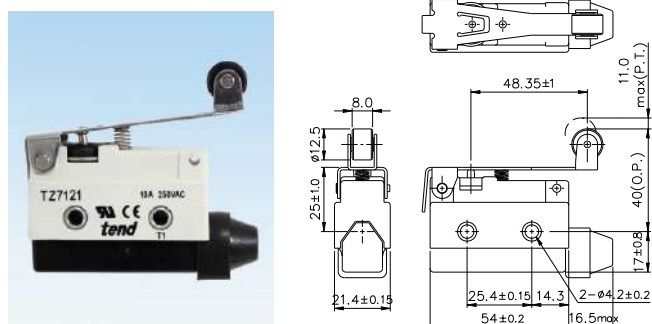

TZ-7141

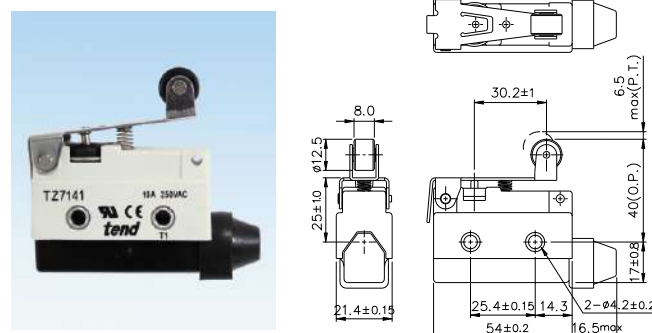

TZ-7310

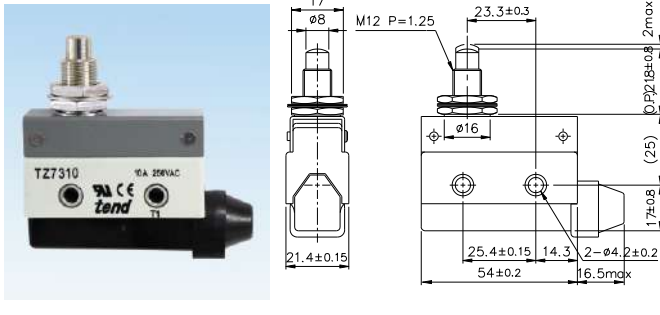

TZ-7110

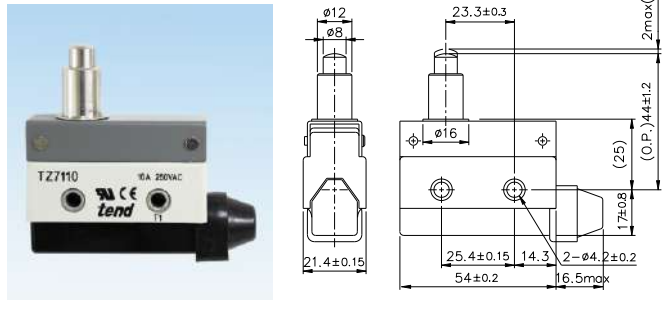

TZ-7311

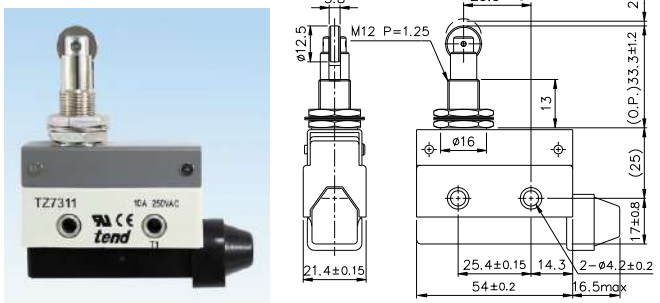

TZ-7100

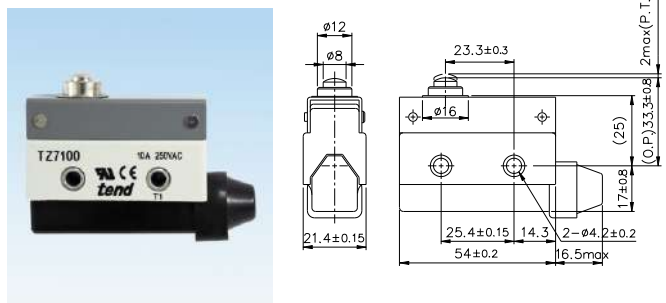

TZ-7312

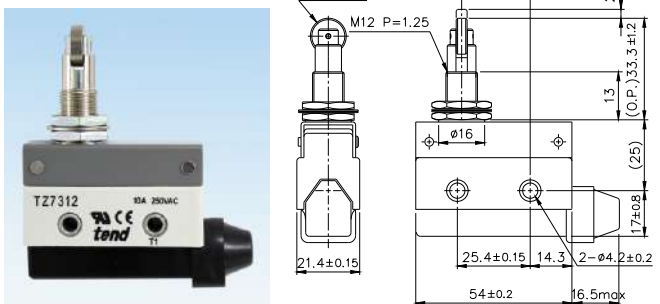

TZ-7124

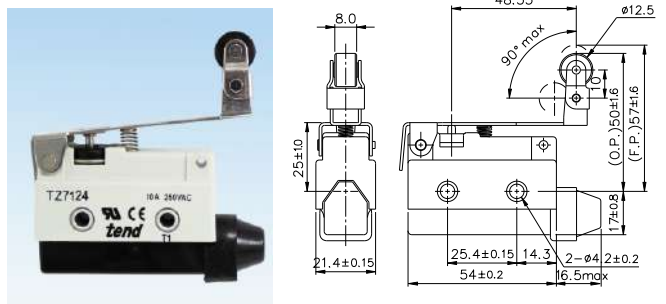

TZ-7120

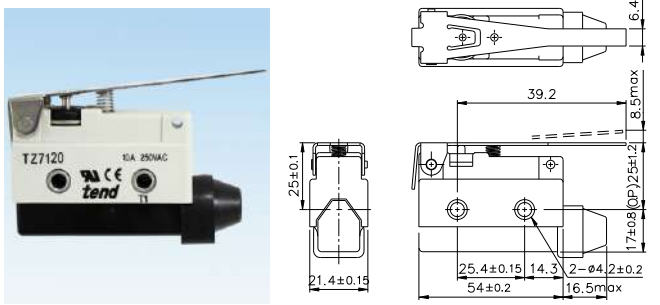

TZ-7144

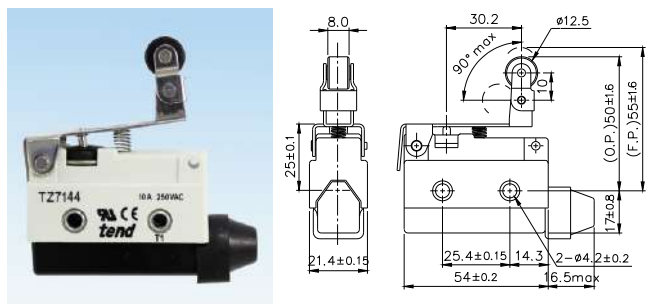

TZ-7140

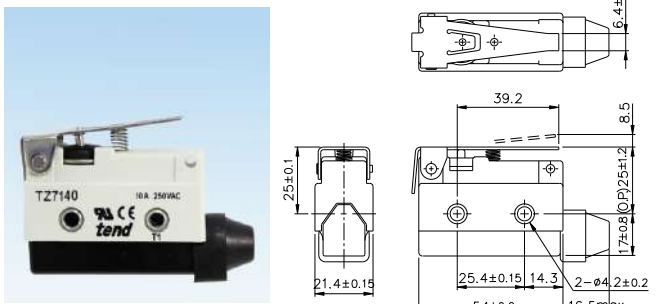

TZ-7166

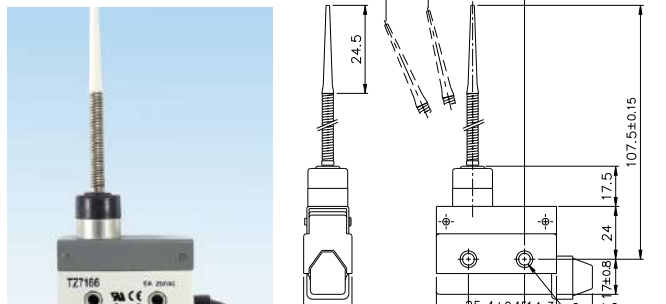

FEATURES

- Built-in basic switch with double spring mechanism
- Long life (10,000,000)mechanical operations)
- Highly rigid construction (head and cover snugly fit in box)
- Dustproof and drip-proof construction
- Smooth operation with greater OT
- Easy-to-wire conduit opening design



CONTACT CONFIGURATION

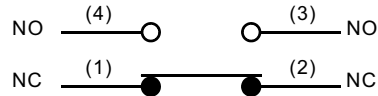

CHARACTERISTICS

Operating speed	0.5mm to 50cm/s
Operating frequency	Mechanically:120 operations/min Electrically:30 operations/min
Contact resistance	15m max. (initial)
Insulation resistance	100M max. (at 500 VDC)
Dielectric strength	1,000VAC,50/60Hz, fo 1minute between non-continuous terminals 1,500VAC,50/60Hz, for 1 1minute between current-carrying and non- current-carring pasts and between each terminal and ground
Vibration	Mechanical durability: 10 to 55HZ,1.5mm double amplitude
Shock	Mechanical durability: 1,000m/S ² (approx. 100G's) malfunction: 500m/S ² (approx. 50G's)
Ambient temperature	Operating:-5 to +65°C
Humidity	95%RH max.
Service life	Mechanically: 10,000,000 operations min. Electrically:500,000 operations min.
weight	Approx.130 to 190g
Degree of protection	IEC : IP65

SPECIFICATIONS

RATINGS

Rated Voltage	Non-inductive				Inductive load			
	Resistive load		Lamp load		Inductive load		Motor load	
	NC	NO	NC	NO	NC	NO	NC	NO
125VAC	5	5	1.5	0.7	3	3	2	1
250VAC	5	5	1	0.5	3	3	1.5	0.8
8 VDC	5	5	3	3	5	4	3	3
14 VDC	5	5	3	3	4	4	3	3
30 VDC	5	5	3	3	4	4	3	3
125 VDC	0.4	0.4						
250 VDC	0.2	0.2						
Inrush current	N.C:24A max.N.O:12Amax							

NOTES:1. inductive load has a power factor of 0.4 min. (Ac) and a time constant of 7 msec. Max.(dc)

2.lamp load has an inrush current of 10 times the steady-state current, while motor load has an inrush current of 6 times the steady-state current.

OPERATION CHARACTERISTICS

Type	TZ-8104	TZ-8108	TZ-8107	TZ-8111	TZ-8112 TZ-8122	TZ-8166 TZ-8167 TZ-8168 TZ-8169
OF Max.	750g	750g	750g	900g	900g	150g
RF Min.	100g	100g	100g	150g	150g	—
PT Max.	20°	20°	20°	1.5mm	1.5mm	30mm
OT Min.	50°	50°	50°	4mm	4mm	—
MD Max.	12°	12°	12°	1mm	1mm	—
OP	—	—	—	26±0.8mm	37±0.8mm	—

TZ-8104

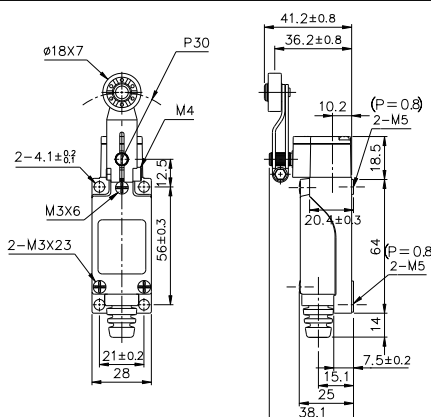

TZ-8108

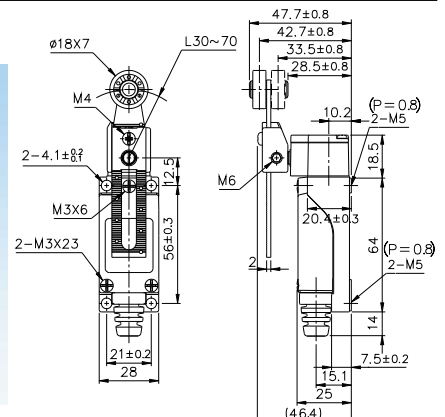

TZ-8107

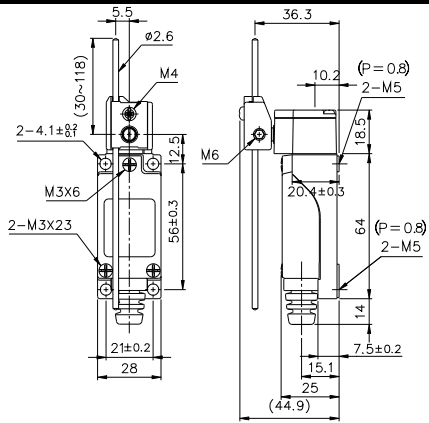

TZ-8112

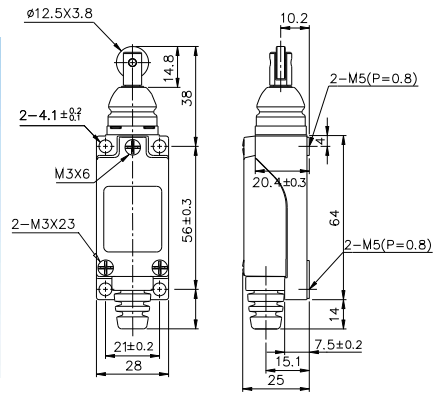

TZ-8111

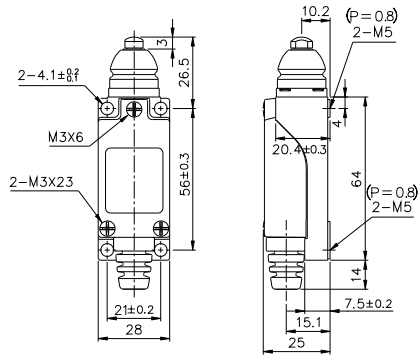

TZ-8122

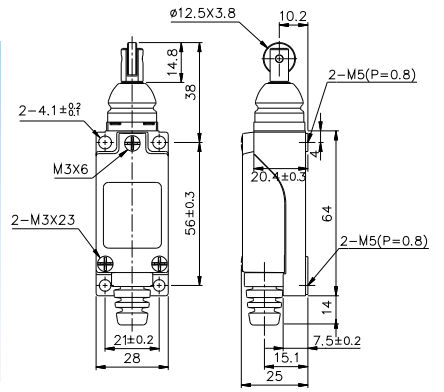

TZ-8166

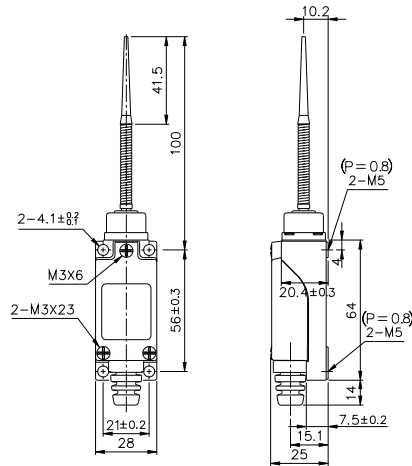

TZ-8167

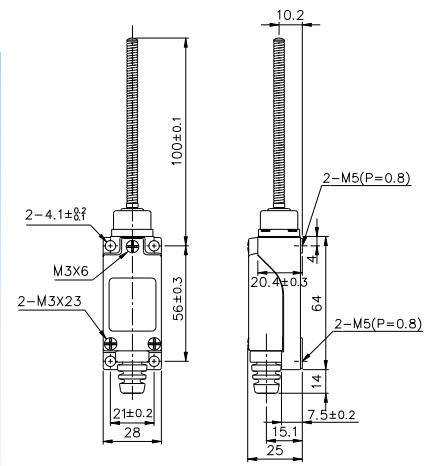

TZ-8168

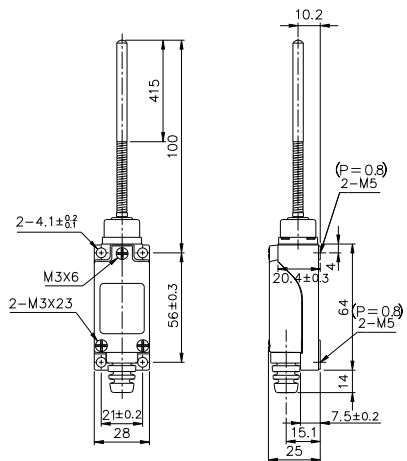

TZ-8169

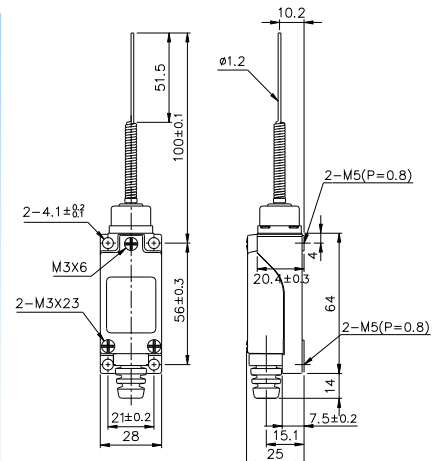

SPECIFICATIONS

- Built-in basic switch with double spring mechanism
- Long life (10,000,000 mechanical operations)
- Material: glass reinforced plastic.
- Dust proof and drip-proof construction
- Smooth operation with greater OT
- Easy-to-wire conduit opening design



CONTACT CONFIGURATION

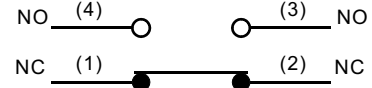

CHARACTERISTICS

Operating speed	0.5mm to 50cm/s
Operating frequency	Mechanically : 120 operations/min. electrically : 30 operations/min.
Contact resistance	25m max. (initial)
Insulation resistance	100M max. (at 500 VDC)
Dielectric strength	1,000VAC, 50/60Hz, for 1minute between non-continuous terminals 1,500VAC, 50/60Hz, for 1minute between current-carrying and non- current-carrying parts and between each terminal and ground
Vibration	Mechanical durability: 10 to 55HZ, 1.5mm double amplitude
Shock	Mechanical durability: 1,000m/S ² (approx. 100G's) malfunction: 300m/S ² (approx. 30G's)
Ambient temperature	Operating: -5 to +65°C
Humidity	95%RH max.
Service life	Mechanically: 10,000,000 operations min. (At rated to value) Electrically: 500,000 operations min
weight	Approx. 70g to 110g
Degree of protection	IEC : IP65

SPECIFICATIONS

RATINGS

Rated Voltage (V)	Non-inductive load(A)				Inductive load(A)			
	Resistive load		Lamp load		Inductive load		Motor load	
	NC	NO	NC	NO	NC	NO	NC	NO
125VAC	5	5	1.5	0.7	3	3	2	1
250VAC	5	5	1	0.5	3	3	1.5	0.8
8 VDC	5	5	3	3	5	4	3	3
14 VDC	5	5	3	3	4	4	3	3
30 VDC	5	5	3	3	4	4	3	3
125 VDC	0.4	0.4						
250 VDC	0.2	0.2						
Inrush current	N.C.:24A max. N.O.:12Amax							

- NOTES: 1. inductive load has a power factor of 0.4 min. (AC) and a time constant of 7 msec. Max. (DC)
2. lamp load has an inrush current of 10 times the steady-state current, while motor load an inrush current of 6 times the steady-state current.

OPERATION CHARACTERISTICS

Type	TZ-9104	TZ-9108	TZ-9107	TZ-9111	TZ-9112 TZ-9122	TZ-9124	TZ-9166 TZ-9167 TZ-9169
	TZ-9204	TZ-9208	TZ-9207	TZ-9211	TZ-9212 TZ-9222	TZ-9224	TZ-9266 TZ-9267 TZ-9269
OF max.	500g	450g	450g	700g	700g	450g	150g
RF min.	50g	40g	40g	150g	150g	80g	—
PT max.	18°~28°	18°~28°	18°~28°	2mm	2mm	4mm	30mm
OT min.	30°	30°	30°	4mm	4mm	5mm	—
MD max.	14°	14°	14°	0.8mm	0.8mm	1.6mm	—
OP	—	—	—	18±0.5mm	28.2±0.8mm	37±0.8mm	—

TZ-92 SERIES CABLE GLAND Diameter of cables: Ø6~12mm HPF12

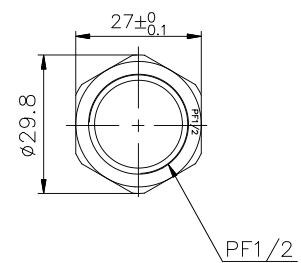
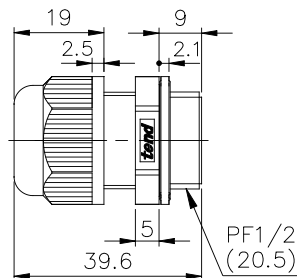
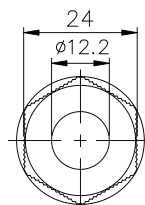

TZ-9104

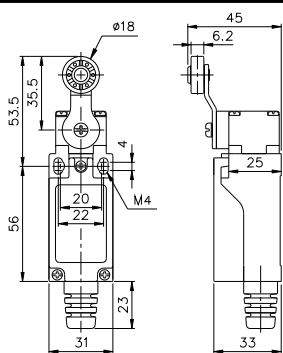

TZ-9108

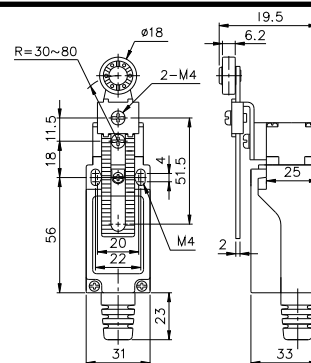

TZ-9107

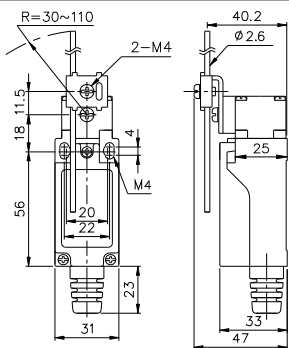

TZ-9111

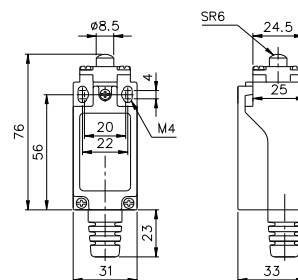

TZ-9112

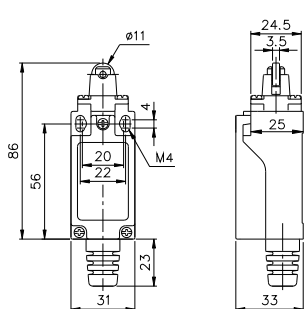

TZ-9122

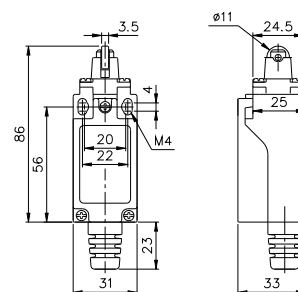

TZ-9124

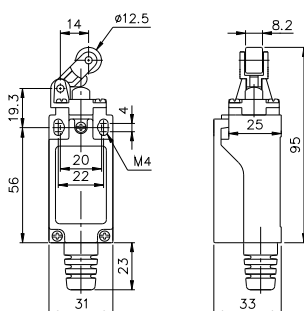

TZ-9166

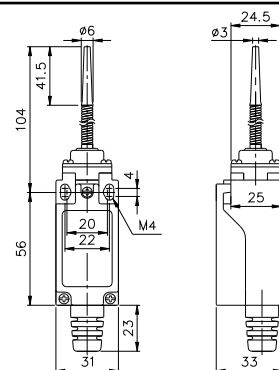

TZ-9167

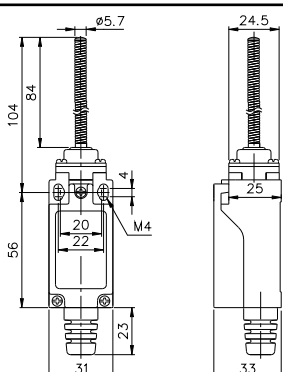

TZ-9169

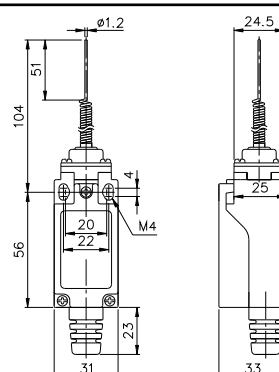

TZ-9204

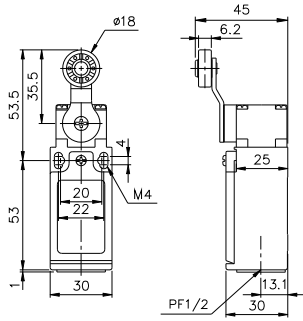

TZ-9208

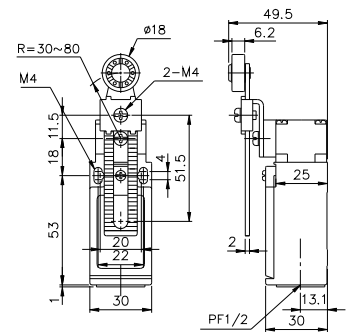

TZ-9207

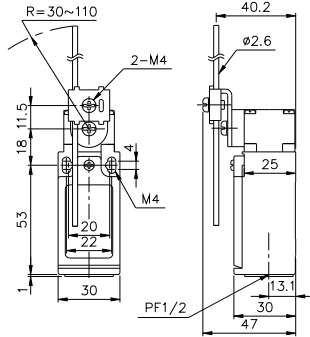

TZ-9211

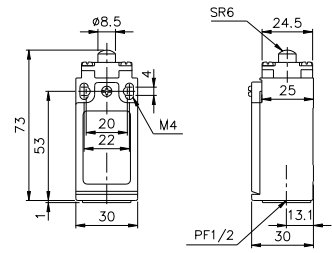

TZ-9212

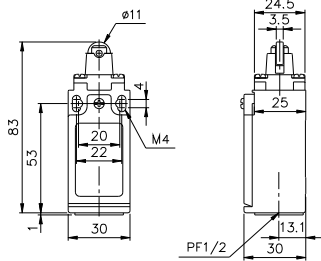

TZ-9222

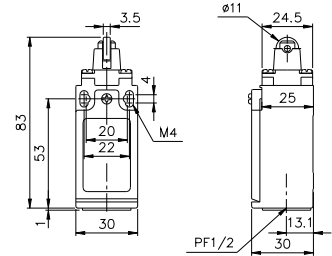

TZ-9224

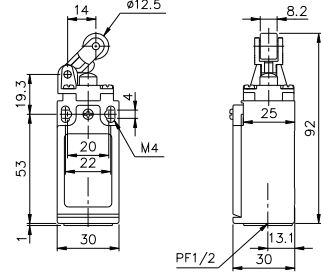

TZ-9266

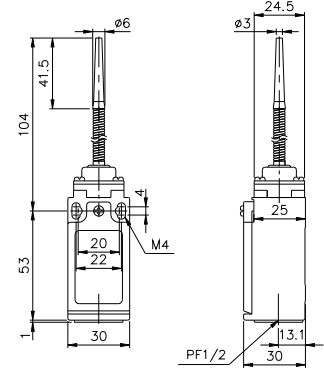

TZ-9267

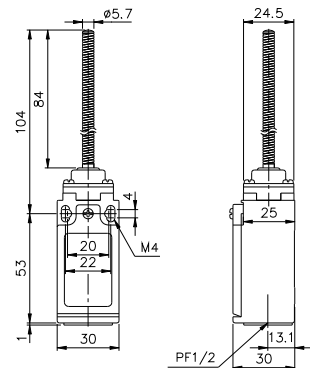

TZ-9269

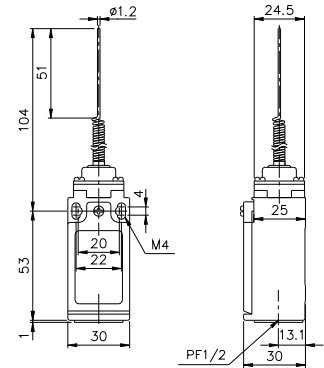



MODEL DESIGNATION

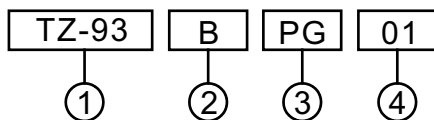

Designation	Signal	Description
1. Type	TZ-93	Safety switch
2. Type of Contact Block Fitted	B	2b
	C	1a1b
3. Conduit Entries	PG	PG13.5xP1.5
	PT	PT1/2x14UNC
4. Actuating keys	None	None
	01	Horizontal
	02	Vertical
	03	Adjustable

SPECIFICATIONS

RATINGS

Rated Voltage (V)	Non-inductive load(A)			Inductive load(A)				
	Resistive load		Lamp load	Inductive load		Motor load		
	NC	NO	NC	NC	NC	NO	NC	NO
125VAC	10	3	1.5	10	5	2.5		
250VAC	10	2	1	10	3	1.5		
400VAC	10	1.5	0.8	3	1.5	0.8		
8VDC	10	6	3	10		6		
14VDC	10	6	3	10		6		
30VDC	6	4	3	6		4		
125VDC	0.8	0.2	0.2	0.8		0.2		
250VDC	0.4	0.1	0.1	0.4		0.1		

USE ATTENTION AFFAIR

- To prevent the wear and the space should be within 1 mm between the key and middle of the insert hole.

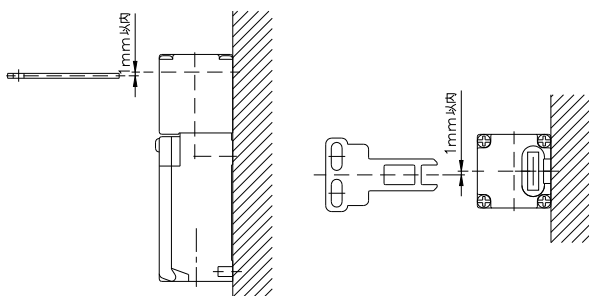

CHARACTERISTICS

Rating	3A 240VAC, (A300)
Operating speed	0.1m~0.5m/s
Operating frequency	30 times/minute
Contact resistance	25m max.(initial)
Insulation resistance	100M min. (At 500VDC)
Rated insulation vantage(Ui)	400V
Dielectric strength	AC2500V/U mip 4KV
Vibration	10~50Hz, 0.65mm double amplitude
Shock	Mechanically: Approx. 1,000m/s ² (Aprox. 100G`s) Electrically: Approx 300m/s ² (Aprox. 100G`s)
Ambient temperature	-30°C~+70°C
Ambient humidity	Below 95%RH
Service life	Mechanically: 10,000,000 operations/min Electrcally: 150,000 operations/min.
Degree of protection	IP65(EN60947-5-1)
Shor-circuit protective device	10A fuse
weight	Approx. 76g

REQUIRED TO HAVE POSITIVE MACHINE

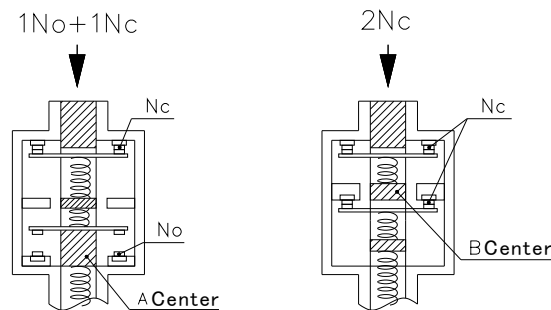

When the contact block get fire, press on the middle of the key structure, the Nc strict leaving structure can push the contact block a way cut off the movement. ⊖

- When in use, there should put a plate on the top to prevent the key overinsert. To prevent nonmovement, the space between the plate and the switch should be under 3 mm.

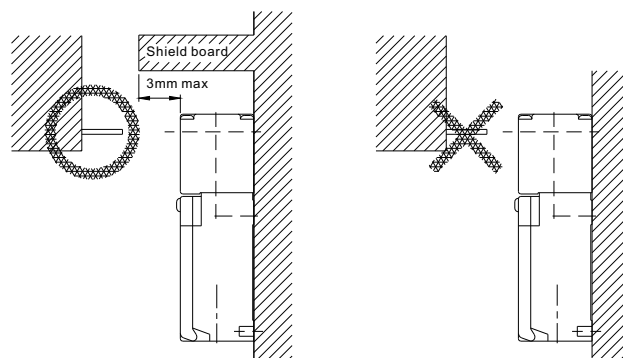

Normal used state

Unsuitable used state

DIMENSIONS

TZ-93BPG
TZ-93BPT
TZ-93CPG
TZ-93CPT

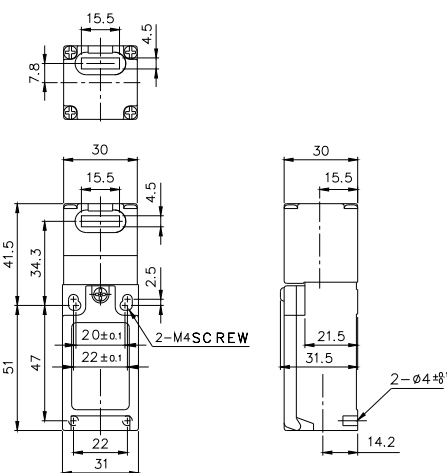

OPERATING CHARACTERISTICS

Key plug in force	max.	14.71N(1,500gf)
Key pull out force	max.	29.42N(3,000gf)
Pre travel		6±3mm
Total travel		(28mm)
Force required to have positive	min.	58.84N(6,000gf)
Positive opening travel	min.	10mm

DIMENSIONS OF OPERATING

TZ-93BPG01
TZ-93BPT01
TZ-93CPG01
TZ-93CPT01

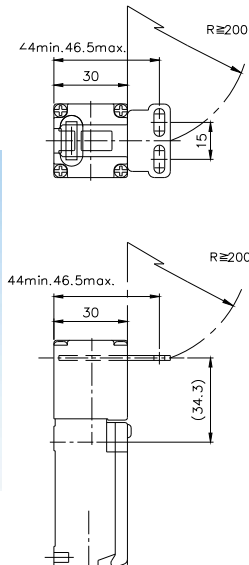

TZ-93BPG02
TZ-93BPT02
TZ-93CPG02
TZ-93CPT02

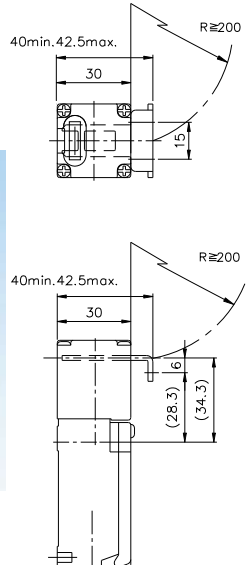

TZ-93BPG03
TZ-93BPT03
TZ-93CPG03
TZ-93CPT03

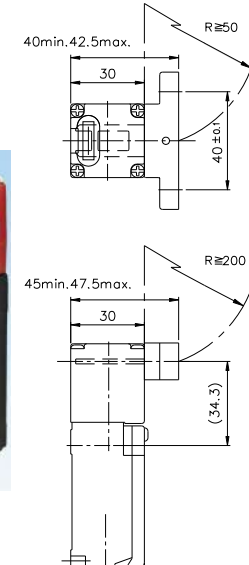

TYPE OF KEYS AND DIMENSIONS

TZ93-K1

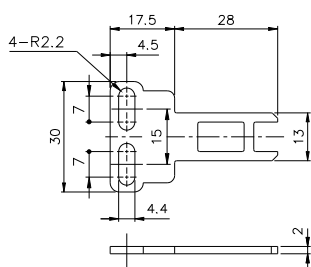

TZ93-K2

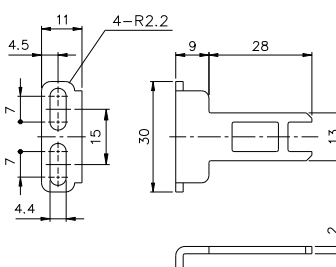

TZ93-K3

