

# Product data sheet

Specifications



## Variable speed drive, Altivar Machine ATV340, 4 kW Heavy Duty, 400 V, 3 phases

ATV340U40N4

**Product availability : Stock - Normally stocked in distribution facility**

**Price\* : 1,006.02 USD**

### Main

Range of Product	Altivar Machine ATV340
Product or Component Type	Variable speed drive
Product Specific Application	Machine
Variant	Standard version
Mounting Mode	Cabinet mount
Communication Port Protocol	Modbus serial
Option card	communication module, Profibus DP V1 communication module, PROFINET communication module, DeviceNet communication module, CANopen communication module, EtherCAT
Phase	3 phase
Supply frequency	50...60 Hz +/- 5 %
[Us] rated supply voltage	380...480 V - 15...10 %
Nominal output current	9.3 A
Motor power kW	5.5 kW normal duty 4 kW heavy duty
Maximum Horse Power Rating	7 hp normal duty 5 hp heavy duty
EMC filter	Class C3 EMC filter integrated
IP degree of protection	IP20

### Complementary

Discrete input number	5
Discrete input type	PT1 programmable as pulse input 0...30 kHz, 24 V DC 30 V) DI1...DI5 safe torque off, 24 V DC 30 V)3.5 kOhm programmable
Number of preset speeds	16 preset speeds
Discrete output number	2.0
Discrete output type	Programmable output DQ1, DQ2 30 V DC 100 mA
Analogue input number	2
Analogue input type	AI1 software-configurable current 0...20 mA 250 Ohm 12 bits AI1 software-configurable temperature probe or water level sensor AI1 software-configurable voltage 0...10 V DC 31.5 kOhm 12 bits

\* Price is "List Price" and may be subject to a trade discount – check with your local distributor or retailer for actual price.

<b>Analogue output number</b>	2
<b>Analogue output type</b>	Software-configurable voltage AQ1 0...10 V DC 470 Ohm 10 bits Software-configurable current AQ1 0...20 mA 500 Ohm 10 bits
<b>Relay output number</b>	2
<b>Output voltage</b>	<= power supply voltage
<b>Relay output type</b>	Relay outputs R1A Relay outputs R1C 100000 cycles Relay outputs R2A Relay outputs R2C 100000 cycles
<b>Maximum switching current</b>	Relay output R1C resistive, cos phi = 1 3 A 250 V AC Relay output R1C resistive, cos phi = 1 3 A 30 V DC Relay output R1C inductive, cos phi = 0.4 7 ms 2 A 250 V AC Relay output R1C inductive, cos phi = 0.4 7 ms 2 A 30 V DC Relay output R2C resistive, cos phi = 1 5 A 250 V AC Relay output R2C resistive, cos phi = 1 5 A 30 V DC Relay output R2C inductive, cos phi = 0.4 7 ms 2 A 250 V AC Relay output R2C inductive, cos phi = 0.4 7 ms 2 A 30 V DC
<b>Minimum switching current</b>	Relay output R1B 5 mA 24 V DC Relay output R2C 5 mA 24 V DC
<b>Physical interface</b>	2-wire RS 485
<b>Connector Type</b>	1 RJ45
<b>Method of access</b>	Slave Modbus RTU
<b>Transmission Rate</b>	4.8 kbit/s 9.6 kbit/s 19.2 kbit/s 38.4 kbit/s
<b>Transmission frame</b>	RTU
<b>Number of addresses</b>	1...247
<b>Data format</b>	8 bits, configurable odd, even or no parity
<b>Type of polarization</b>	No impedance
<b>4 quadrant operation possible</b>	True
<b>Asynchronous motor control profile</b>	Constant torque standard Variable torque standard Optimized torque mode
<b>Synchronous motor control profile</b>	Permanent magnet motor Reluctance motor
<b>Pollution degree</b>	2 EN/IEC 61800-5-1
<b>Maximum output frequency</b>	0.599 kHz
<b>Acceleration and deceleration ramps</b>	Linear adjustable separately from 0.01...9999 s S, U or customized
<b>Motor slip compensation</b>	Automatic whatever the load Not available in permanent magnet motor law Adjustable Can be suppressed
<b>Switching frequency</b>	2...16 kHz adjustable 4...16 kHz with derating factor
<b>Nominal switching frequency</b>	4 kHz
<b>Braking to standstill</b>	By DC injection
<b>Brake chopper integrated</b>	True
<b>Line current</b>	11.4 A 380 V normal duty) 9.0 A 480 V normal duty) 13.4 A 380 V heavy duty) 10.6 A 480 V heavy duty)  13.4 A 380 V without line choke heavy duty) 10.6 A 480 V without line choke heavy duty) 11.4 A 380 V with external line choke normal duty) 9 A 480 V with external line choke normal duty) 8.5 A 380 V with external line choke heavy duty) 6.8 A 480 V with external line choke heavy duty)

<b>Maximum Input Current per Phase</b>	13.4 A
<b>Maximum output voltage</b>	480 V
<b>Apparent power</b>	9 kVA 480 V normal duty) 8.8 kVA 480 V heavy duty)
<b>Maximum transient current</b>	14 A 60 s normal duty) 14 A 60 s heavy duty) 17.1 A 2 s normal duty) 16.7 A 2 s heavy duty)
<b>Electrical connection</b>	Screw terminal 1.5...4 mm <sup>2</sup> line side Screw terminal 4...6 mm <sup>2</sup> DC bus Screw terminal 1.5...4 mm <sup>2</sup> motor Screw terminal 0.2...2.5 mm <sup>2</sup> control
<b>Prospective line I<sub>sc</sub></b>	5 kA
<b>Base load current at high overload</b>	9.3 A
<b>Base load current at low overload</b>	12.7 A
<b>Power dissipation in W</b>	Natural convection 99 W 380 V 4 kHz heavy duty) Forced convection 99 W 380 V 4 kHz heavy duty) Natural convection 130 W 380 V 4 kHz normal duty) Forced convection 130 W 380 V 4 kHz normal duty)  Line side screw terminal 1.5...4 mm <sup>2</sup> AWG 14...AWG 12 DC bus screw terminal 4...6 mm <sup>2</sup> AWG 12...AWG 10 Motor screw terminal 1.5...4 mm <sup>2</sup> AWG 14...AWG 12 Control screw terminal 0.2...2.5 mm <sup>2</sup> AWG 24...AWG 12
<b>With safety function Safely Limited Speed (SLS)</b>	True
<b>With safety function Safe brake management (SBC/SBT)</b>	True
<b>With safety function Safe Operating Stop (SOS)</b>	False
<b>With safety function Safe Position (SP)</b>	False
<b>With safety function Safe programmable logic</b>	False
<b>With safety function Safe Speed Monitor (SSM)</b>	False
<b>With safety function Safe Stop 1 (SS1)</b>	True
<b>With sft fct Safe Stop 2 (SS2)</b>	False
<b>With safety function Safe torque off (STO)</b>	True
<b>With safety function Safely Limited Position (SLP)</b>	False
<b>With safety function Safe Direction (SDI)</b>	False
<b>Protection type</b>	Thermal protection motor Safe torque off motor Motor phase loss motor Thermal protection drive Safe torque off drive Overheating drive Overcurrent drive Output overcurrent between motor phase and earth drive Output overcurrent between motor phases drive Short-circuit between motor phase and earth drive Short-circuit between motor phases drive Motor phase loss drive DC Bus overvoltage drive Line supply overvoltage drive Line supply undervoltage drive Input supply loss drive Exceeding limit speed drive Break on the control circuit drive

<b>Width</b>	3.35 in (85.0 mm)
<b>Height</b>	10.63 in (270.0 mm)
<b>Depth</b>	9.15 in (232.5 mm)
<b>Net Weight</b>	4.85 lb(US) (2.2 kg)
<b>Continuous output current</b>	12.7 A 4 kHz normal duty 9.3 A 4 kHz heavy duty

## Environment

<b>Operating altitude</b>	<= 9842.52 ft (3000 m) with current derating above 1000m
<b>Operating position</b>	Vertical +/- 10 degree
<b>Product Certifications</b>	UL CSA TÜV EAC CTick
<b>Marking</b>	CE
<b>Standards</b>	EN/IEC 61800-3 EN/IEC 61800-5-1 IEC 60721-3 IEC 61508 IEC 13849-1 UL 618000-5-1 UL 508C
<b>Assembly style</b>	With heat sink
<b>Electromagnetic compatibility</b>	Electrostatic discharge immunity test level 3 IEC 61000-4-2 Radiated radio-frequency electromagnetic field immunity test level 3 IEC 61000-4-3 Electrical fast transient/burst immunity test level 4 IEC 61000-4-4 1.2/50 µs - 8/20 µs surge immunity test level 3 IEC 61000-4-5 Conducted radio-frequency immunity test level 3 IEC 61000-4-6
<b>Environmental class (during operation)</b>	Class 3C3 according to IEC 60721-3-3 Class 3S3 according to IEC 60721-3-3
<b>Maximum acceleration under shock impact (during operation)</b>	70 m/s <sup>2</sup> at 22 ms
<b>Maximum acceleration under vibrational stress (during operation)</b>	5 m/s <sup>2</sup> at 9...200 Hz
<b>Maximum deflection under vibratory load (during operation)</b>	1.5 mm at 2...9 Hz
<b>Permitted relative humidity (during operation)</b>	Class 3K5 according to EN 60721-3
<b>Volume of cooling air</b>	5019.36 Gal/hr(US) (19.0 m3/h)
<b>Type of cooling</b>	Forced convection
<b>Overvoltage category</b>	Class III
<b>Regulation loop</b>	Adjustable PID regulator
<b>Noise level</b>	49.5 dB  2
<b>Ambient air transport temperature</b>	-40...158 °F (-40...70 °C)
<b>Ambient air temperature for operation</b>	5...122 °F (-15...50 °C) without derating vertical position) 122...140 °F (50...60 °C) with derating factor vertical position)
<b>Ambient Air Temperature for Storage</b>	-40...158 °F (-40...70 °C)
<b>Isolation</b>	Between power and control terminals

## Ordering and shipping details

Category	22182-ATV340 (1 THRU 25 HP)
Discount Schedule	CP4B
GTIN	3606480966910
Returnability	Yes
Country of origin	ID

## Packing Units

Unit Type of Package 1	PCE
Number of Units in Package 1	1
Package 1 Height	4.33 in (11.000 cm)
Package 1 Width	14.57 in (37.000 cm)
Package 1 Length	12.60 in (32.000 cm)
Package 1 Weight	6.50 lb(US) (2.950 kg)
Unit Type of Package 2	P06
Number of Units in Package 2	14
Package 2 Height	29.53 in (75.000 cm)
Package 2 Width	23.62 in (60.000 cm)
Package 2 Length	31.50 in (80.000 cm)
Package 2 Weight	119.71 lb(US) (54.300 kg)

## Offer Sustainability

Sustainable offer status	Green Premium product
California proposition 65	WARNING: This product can expose you to chemicals including: Lead and lead compounds, which is known to the State of California to cause cancer and birth defects or other reproductive harm. For more information go to <a href="http://www.P65Warnings.ca.gov">www.P65Warnings.ca.gov</a>
REACH Regulation	<a href="#">REACH Declaration</a>
EU RoHS Directive	Pro-active compliance (Product out of EU RoHS legal scope) <a href="#">EU RoHS Declaration</a>
Mercury free	Yes
China RoHS Regulation	<a href="#">China RoHS declaration</a>
RoHS exemption information	Yes
Environmental Disclosure	<a href="#">Product Environmental Profile</a>
Circularity Profile	<a href="#">End of Life Information</a>
WEEE	The product must be disposed on European Union markets following specific waste collection and never end up in rubbish bins.
Upgradeability	Upgraded components available

## Dimensions

### Views: Front - Left - Rear

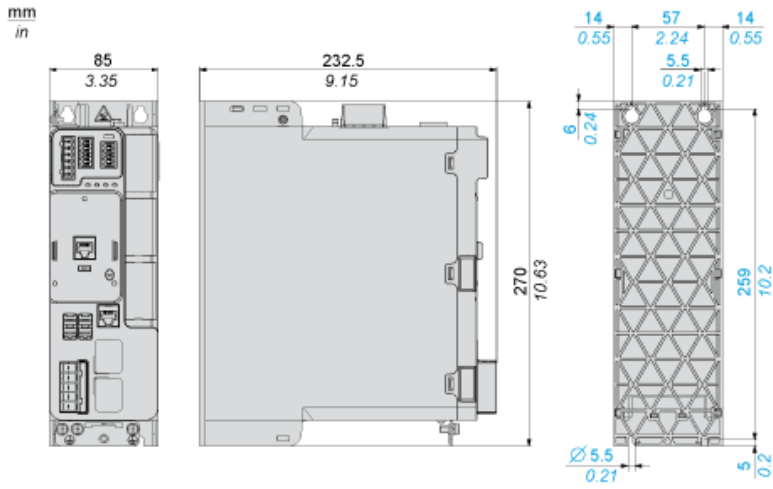

**Clearance**

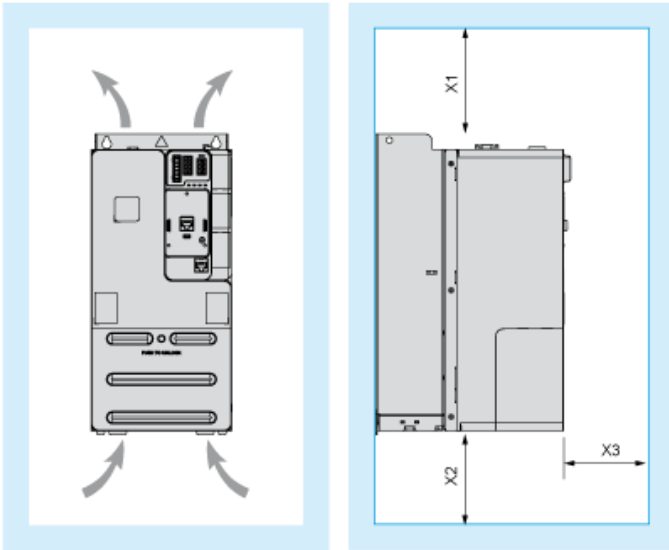

**Dimensions in mm**

X1	X2	X3
≥ 100	≥ 100	≥ 60

**Dimensions in in.**

X1	X2	X3
≥ 3.94	≥ 3.94	≥ 2.36

**Mounting Types**

---

**Mounting Type A: Side by Side IP20**

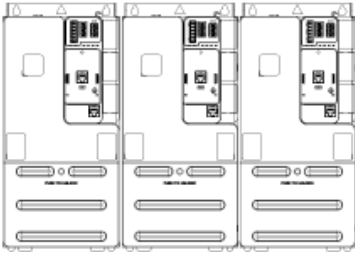

Possible, at ambient temperature  $\leq 50\text{ }^{\circ}\text{C}$  (122  $^{\circ}\text{F}$ )

**Mounting Type B: Individual IP20**

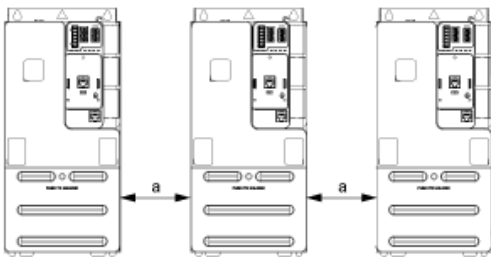

$a \geq 50\text{ mm}$  (1.97 in.) from 50...60 $^{\circ}\text{C}$ , no restriction below 50 $^{\circ}\text{C}$



**Connections and Schema**

**Three-phase Power Supply with Upstream Breaking via Line Contactor Without Safety Function STO**

Connection diagrams conforming to standards ISO13849 category 1 and IEC/EN 61508 capacity SIL1, stopping category 0 in accordance with standard IEC/EN 60204-1.

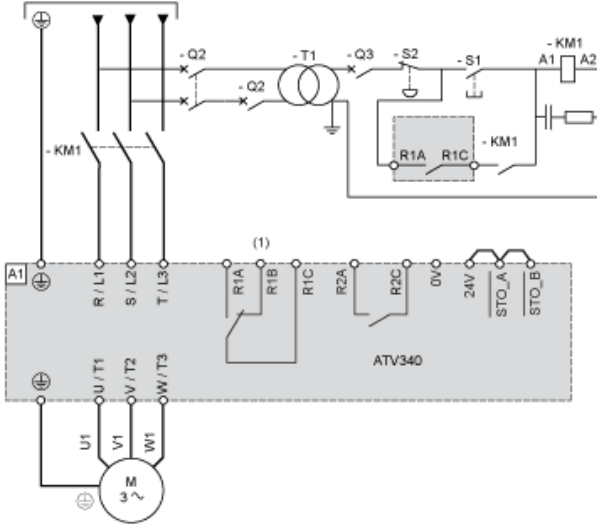

- (1) Use relay output R1 set to operating state Fault to switch Off the product once an error is detected.
- A1 : Drive
- KM1 : Line Contactor
- Q2, Q3 : Circuit breakers
- S1 : Pushbutton
- S2 : Emergency stop
- T1 : Transformer for control part

**Three-phase Power Supply With Downstream Breaking via Switch Disconnecter**

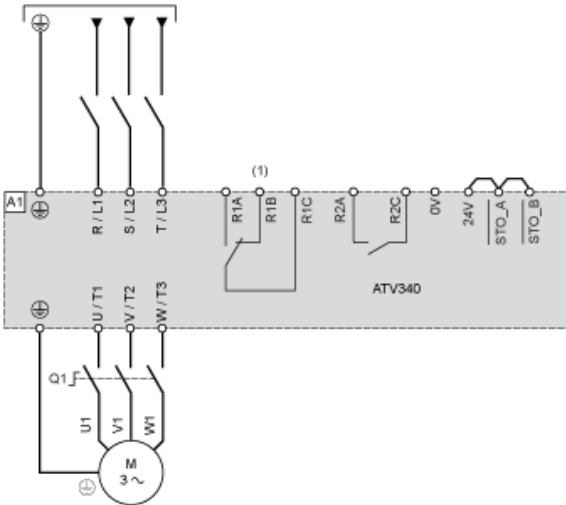

- (1) Use relay output R1 set to operating state Fault to switch Off the product once an error is detected.
- A1 : Drive
- Q1 : Switch disconnecter

**Sensor Connection**

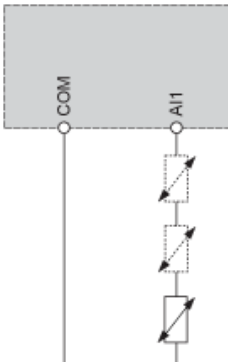

It is possible to connect either 1 or 3 sensors on terminals A11.

**Control Block Wiring Diagram**

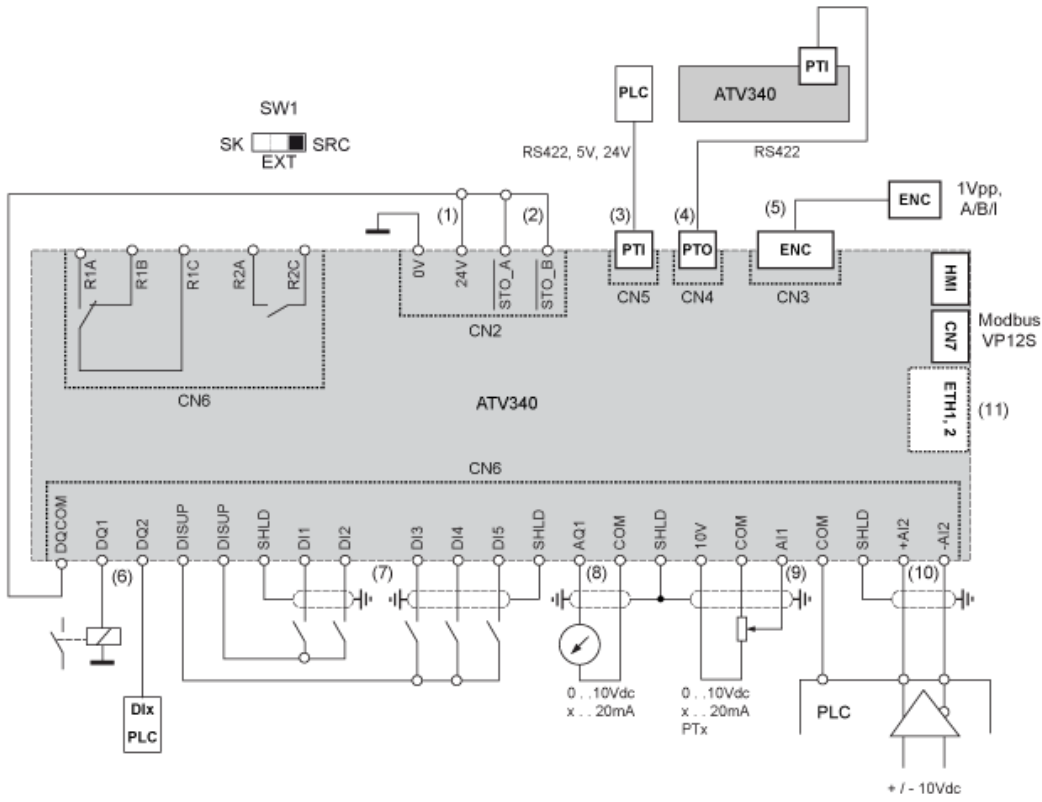

- (1) 24V supply (STO)
  - (2) STO - Safe Torque Off
  - (3) PTI - Pulse Train In
  - (4) PTO - Pulse Train Out
  - (5) Motor Encoder connection
  - (6) Digital outputs
  - (7) Digital inputs
  - (8) Analog output
  - (9) Analog input
  - (10) Differential Analog Input
  - (11) Ethernet port (only on Ethernet drive version)
- SW1 : Sink/Source switch  
R1A, R1B, R1C : Relay  
R2A, R2C : Sequence relay

**Digital Inputs Wiring**

**Digital Inputs: Internal Supply**

Using DISUP Signal

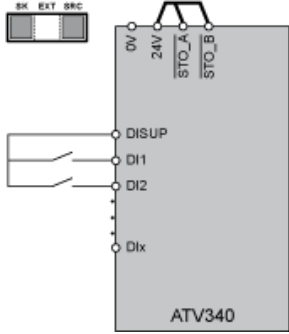

In SRC position DISUP outputs 24 V. In SK position DISUP is connected to 0 V.

**Digital Inputs: External Supply**

Positive Logic, Source, European Style

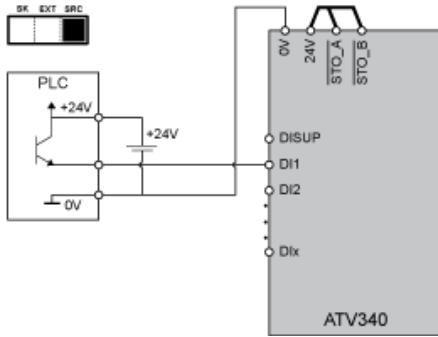

**Negative Logic, Sink, Asian Style**

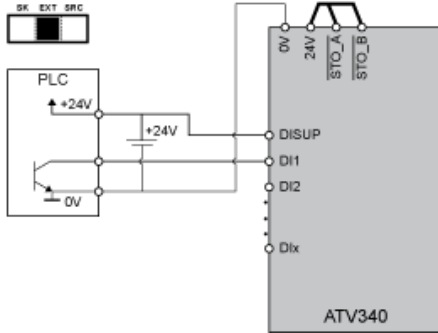

**Digital Inputs: Internal supply**

Negative Logic, Sink, Asian Style

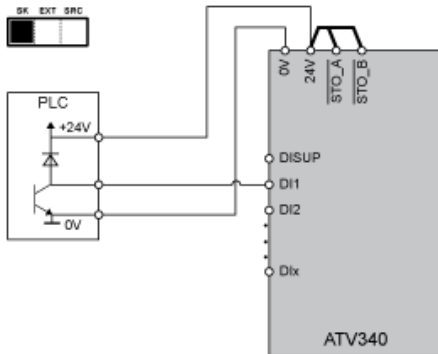

## Digital Outputs Wiring

### Digital Outputs: Internal Supply

Positive Logic, Source, European Style, DQCOM to +24V

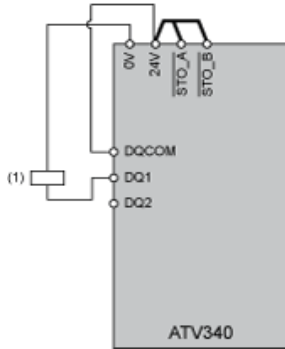

(1) Relay or valve

Negative Logic, Sink, Asian Style, DQCOM to 0V

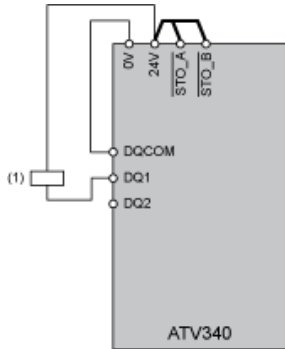

(1) Relay or valve

### Digital Outputs: External Supply

Positive Logic, Source, European Style, DQCOM to +24V

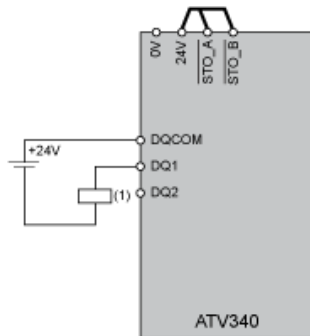

(1) Relay or valve

Negative Logic, Sink, Asian Style, DQCOM to 0V

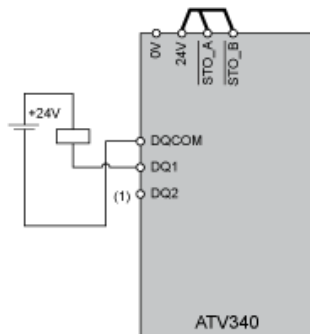

(1) Relay or valve

Open Loop Applications

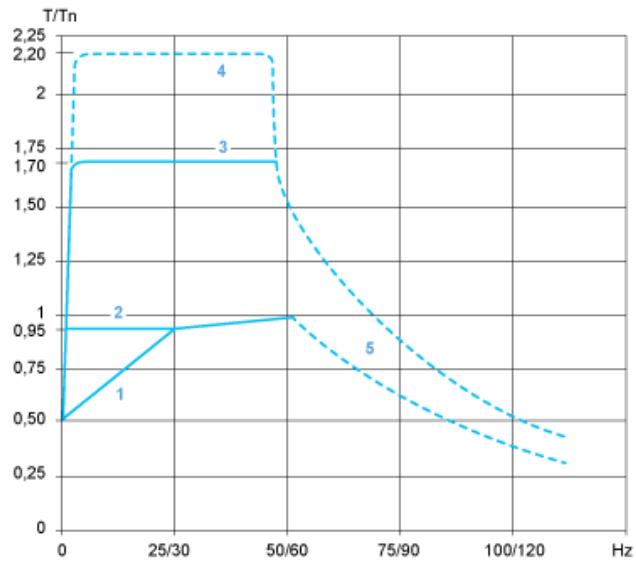

- 1 : Self-cooled motor: continuous useful torque
- 2 : Force-cooled motor: continuous useful torque
- 3 : Overtorque for 60 s maximum
- 4 : Transient overtorque for 2 s maximum
- 5 : Torque in overspeed at constant power

Closed Loop Applications

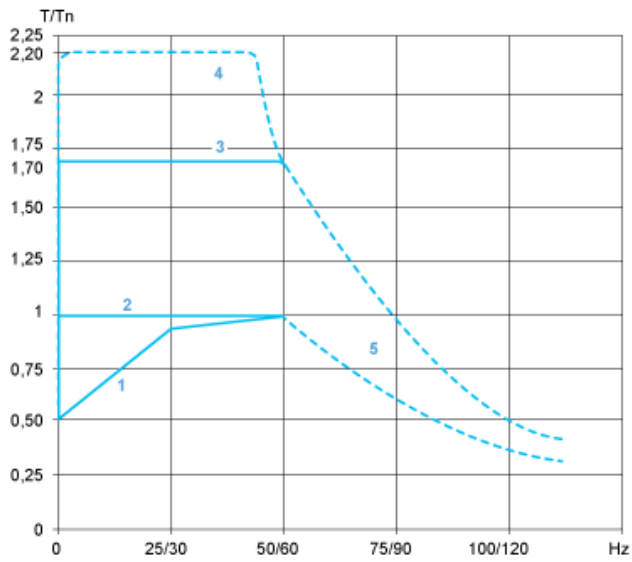

- 1 : Self-cooled motor: continuous useful torque
- 2 : Force-cooled motor: continuous useful torque
- 3 : Overtorque for 60 s maximum
- 4 : Transient overtorque for 2 s maximum
- 5 : Torque in overspeed at constant power

Recommended replacement(s)