

# Product datasheet

Specifications



## Variable speed drive, Altivar Machine ATV340, 11 kW Heavy Duty, 400 V, 3 phases

ATV340D11N4

### Main

Range of product	Altivar Machine ATV340
Product or component type	Variable speed drive
Product specific application	Machine
Variant	Standard version
Mounting mode	Cabinet mount
Communication port protocol	Modbus serial
Option card	Communication module, Profibus DP V1 Communication module, PROFINET Communication module, DeviceNet Communication module, CANopen Communication module, EtherCAT
Network number of phases	3 phases
Supply frequency	50...60 Hz +/- 5 %
[Us] rated supply voltage	380...480 V - 15...10 %
Nominal output current	24.0 A
Motor power kW	15 kW for normal duty 11 kW for heavy duty
Motor power hp	20 hp for normal duty 15 hp for heavy duty
EMC filter	Class C3 EMC filter integrated
IP degree of protection	IP20

### Complementary

Discrete input number	5
Discrete input type	PT1 programmable as pulse input: 0...30 kHz, 24 V DC (30 V) DI1...DI5 programmable, 24 V DC (30 V), impedance: 3.5 kOhm
Number of preset speeds	16 preset speeds
Discrete output number	2.0
Discrete output type	Programmable output DQ1, DQ2 30 V DC 100 mA
Analogue input number	2
Analogue input type	A11 software-configurable current: 0...20 mA, impedance: 250 Ohm, resolution 12 bits A11 software-configurable temperature probe or water level sensor A11 software-configurable voltage: 0...10 V DC, impedance: 31.5 kOhm, resolution 12 bits A12 software-configurable voltage: - 10...10 V DC, impedance: 31.5 kOhm, resolution 12 bits
Analogue output number	2

<b>Analogue output type</b>	Software-configurable voltage AQ1: 0...10 V DC impedance 470 Ohm, resolution 10 bits Software-configurable current AQ1: 0...20 mA impedance 500 Ohm, resolution 10 bits
<b>Relay output number</b>	2
<b>Output voltage</b>	<= power supply voltage
<b>Relay output type</b>	Relay outputs R1A Relay outputs R1C electrical durability 100000 cycles Relay outputs R2A Relay outputs R2C electrical durability 100000 cycles
<b>Maximum switching current</b>	Relay output R1C on resistive load, cos phi = 1: 3 A at 250 V AC Relay output R1C on resistive load, cos phi = 1: 3 A at 30 V DC Relay output R1C on inductive load, cos phi = 0.4 and L/R = 7 ms: 2 A at 250 V AC Relay output R1C on inductive load, cos phi = 0.4 and L/R = 7 ms: 2 A at 30 V DC Relay output R2C on resistive load, cos phi = 1: 5 A at 250 V AC Relay output R2C on resistive load, cos phi = 1: 5 A at 30 V DC Relay output R2C on inductive load, cos phi = 0.4 and L/R = 7 ms: 2 A at 250 V AC Relay output R2C on inductive load, cos phi = 0.4 and L/R = 7 ms: 2 A at 30 V DC
<b>Minimum switching current</b>	Relay output R1B: 5 mA at 24 V DC Relay output R2C: 5 mA at 24 V DC
<b>Physical interface</b>	2-wire RS 485
<b>Connector type</b>	1 RJ45
<b>Method of access</b>	Slave Modbus RTU
<b>Transmission rate</b>	4.8 kbit/s 9.6 kbit/s 19.2 kbit/s 38.4 kbit/s
<b>Transmission frame</b>	RTU
<b>Number of addresses</b>	1...247
<b>Data format</b>	8 bits, configurable odd, even or no parity
<b>Type of polarization</b>	No impedance
<b>4 quadrant operation possible</b>	True
<b>Asynchronous motor control profile</b>	Optimized torque mode Variable torque standard Constant torque standard
<b>Synchronous motor control profile</b>	Permanent magnet motor Reluctance motor
<b>Pollution degree</b>	2 conforming to EN/IEC 61800-5-1
<b>Maximum output frequency</b>	0.599 kHz
<b>Acceleration and deceleration ramps</b>	Linear adjustable separately from 0.01...9999 s S, U or customized
<b>Motor slip compensation</b>	Not available in permanent magnet motor law Adjustable Can be suppressed Automatic whatever the load
<b>Switching frequency</b>	2...16 kHz adjustable 4...16 kHz with derating factor
<b>Nominal switching frequency</b>	4 kHz
<b>Braking to standstill</b>	By DC injection
<b>Brake chopper integrated</b>	True
<b>Line current</b>	28.8 A at 380 V (normal duty) 23.0 A at 480 V (normal duty) 34.7 A at 380 V (heavy duty) 27.7 A at 480 V (heavy duty)  34.7 A at 380 V without line choke (heavy duty) 27.7 A at 480 V without line choke (heavy duty) 33.9 A at 380 V with external line choke (normal duty) 27.2 A at 480 V with external line choke (normal duty) 35.1 A at 380 V with external line choke (heavy duty) 27.8 A at 480 V with external line choke (heavy duty)
<b>Maximum input current</b>	34.7 A
<b>Maximum output voltage</b>	480 V

<b>Apparent power</b>	22.7 kVA at 480 V (normal duty) 23 kVA at 480 V (heavy duty)
<b>Maximum transient current</b>	35.2 A during 60 s (normal duty) 36 A during 60 s (heavy duty) 43.2 A during 2 s (normal duty) 43 A during 2 s (heavy duty)
<b>Electrical connection</b>	Screw terminal, clamping capacity: 0.2...2.5 mm <sup>2</sup> for control Screw terminal, clamping capacity: 4...25 mm <sup>2</sup> for line side Screw terminal, clamping capacity: 4...25 mm <sup>2</sup> for DC bus Screw terminal, clamping capacity: 2.5...25 mm <sup>2</sup> for motor
<b>Prospective line I<sub>sc</sub></b>	22 kA
<b>Base load current at high overload</b>	24.0 A
<b>Base load current at low overload</b>	32.0 A
<b>Power dissipation in W</b>	Natural convection: 13 W at 380 V, switching frequency 4 kHz (heavy duty) Forced convection: 241 W at 380 V, switching frequency 4 kHz (heavy duty) Natural convection: 16 W at 380 V, switching frequency 4 kHz (normal duty) Forced convection: 311 W at 380 V, switching frequency 4 kHz (normal duty)  Control: screw terminal 0.2...2.5 mm <sup>2</sup> /AWG 24...AWG 12 Line side: screw terminal 4...25 mm <sup>2</sup> /AWG 10...AWG 3 DC bus: screw terminal 4...25 mm <sup>2</sup> /AWG 10...AWG 3 Motor: screw terminal 2.5...25 mm <sup>2</sup> /AWG 12...AWG 3
<b>With safety function Safely Limited Speed (SLS)</b>	True
<b>With safety function Safe brake management (SBC/SBT)</b>	True
<b>With safety function Safe Operating Stop (SOS)</b>	False
<b>With safety function Safe Position (SP)</b>	False
<b>With safety function Safe programmable logic</b>	False
<b>With safety function Safe Speed Monitor (SSM)</b>	False
<b>With safety function Safe Stop 1 (SS1)</b>	True
<b>With sft fct Safe Stop 2 (SS2)</b>	False
<b>With safety function Safe torque off (STO)</b>	True
<b>With safety function Safely Limited Position (SLP)</b>	False
<b>With safety function Safe Direction (SDI)</b>	False
<b>Protection type</b>	Thermal protection: motor Safe torque off: motor Motor phase loss: motor Thermal protection: drive Safe torque off: drive Overheating: drive Overcurrent: drive Output overcurrent between motor phase and earth: drive Output overcurrent between motor phases: drive Short-circuit between motor phase and earth: drive Short-circuit between motor phases: drive Motor phase loss: drive DC Bus overvoltage: drive Line supply overvoltage: drive Line supply undervoltage: drive Input supply loss: drive Exceeding limit speed: drive Break on the control circuit: drive
<b>Width</b>	180.0 mm
<b>Height</b>	385.0 mm
<b>Depth</b>	249.0 mm

<b>Net weight</b>	9.5 kg
<b>Continuous output current</b>	32 A at 4 kHz for normal duty 24 A at 4 kHz for heavy duty
<b>Environment</b>	
<b>Operating altitude</b>	<= 3000 m with current derating above 1000m
<b>Operating position</b>	Vertical +/- 10 degree
<b>Product certifications</b>	UL CSA TÜV EAC CTick
<b>Marking</b>	CE
<b>Standards</b>	EN/IEC 61800-3 EN/IEC 61800-5-1 IEC 60721-3 IEC 61508 IEC 13849-1 UL 618000-5-1 UL 508C
<b>Assembly style</b>	With heat sink
<b>Electromagnetic compatibility</b>	Electrostatic discharge immunity test level 3 conforming to IEC 61000-4-2 Radiated radio-frequency electromagnetic field immunity test level 3 conforming to IEC 61000-4-3 Electrical fast transient/burst immunity test level 4 conforming to IEC 61000-4-4 1.2/50 µs - 8/20 µs surge immunity test level 3 conforming to IEC 61000-4-5 Conducted radio-frequency immunity test level 3 conforming to IEC 61000-4-6
<b>Environmental class (during operation)</b>	Class 3C3 according to IEC 60721-3-3 Class 3S3 according to IEC 60721-3-3
<b>Maximum acceleration under shock impact (during operation)</b>	70 m/s <sup>2</sup> at 22 ms
<b>Maximum acceleration under vibrational stress (during operation)</b>	5 m/s <sup>2</sup> at 9...200 Hz
<b>Maximum deflection under vibratory load (during operation)</b>	1.5 mm at 2...9 Hz
<b>Permitted relative humidity (during operation)</b>	Class 3K5 according to EN 60721-3
<b>Volume of cooling air</b>	128.0 m <sup>3</sup> /h
<b>Type of cooling</b>	Forced convection
<b>Overtoltage category</b>	Class III
<b>Regulation loop</b>	Adjustable PID regulator
<b>Noise level</b>	55.6 dB  2
<b>Ambient air transport temperature</b>	-40...70 °C
<b>Ambient air temperature for operation</b>	-15...50 °C without derating (vertical position) 50...60 °C with derating factor (vertical position)
<b>Ambient air temperature for storage</b>	-40...70 °C
<b>Isolation</b>	Between power and control terminals

## Packing Units

<b>Unit Type of Package 1</b>	PCE
<b>Number of Units in Package 1</b>	1
<b>Package 1 Height</b>	34.000 cm

Package 1 Width	30.500 cm
Package 1 Length	56.500 cm
Package 1 Weight	11.206 kg
Unit Type of Package 2	P06
Number of Units in Package 2	2
Package 2 Height	75.000 cm
Package 2 Width	60.000 cm
Package 2 Length	80.000 cm
Package 2 Weight	35.412 kg

## Offer Sustainability

Sustainable offer status	Green Premium product
REACH Regulation	<a href="#">REACH Declaration</a>
EU RoHS Directive	Pro-active compliance (Product out of EU RoHS legal scope) <a href="#">EU RoHS Declaration</a>
Mercury free	Yes
China RoHS Regulation	<a href="#">China RoHS declaration</a>
RoHS exemption information	Yes
Environmental Disclosure	<a href="#">Product Environmental Profile</a>
Circularity Profile	<a href="#">End of Life Information</a>
WEEE	The product must be disposed on European Union markets following specific waste collection and never end up in rubbish bins
Upgradeability	Upgraded components available

## Dimensions

Views: Front - Left - Rear

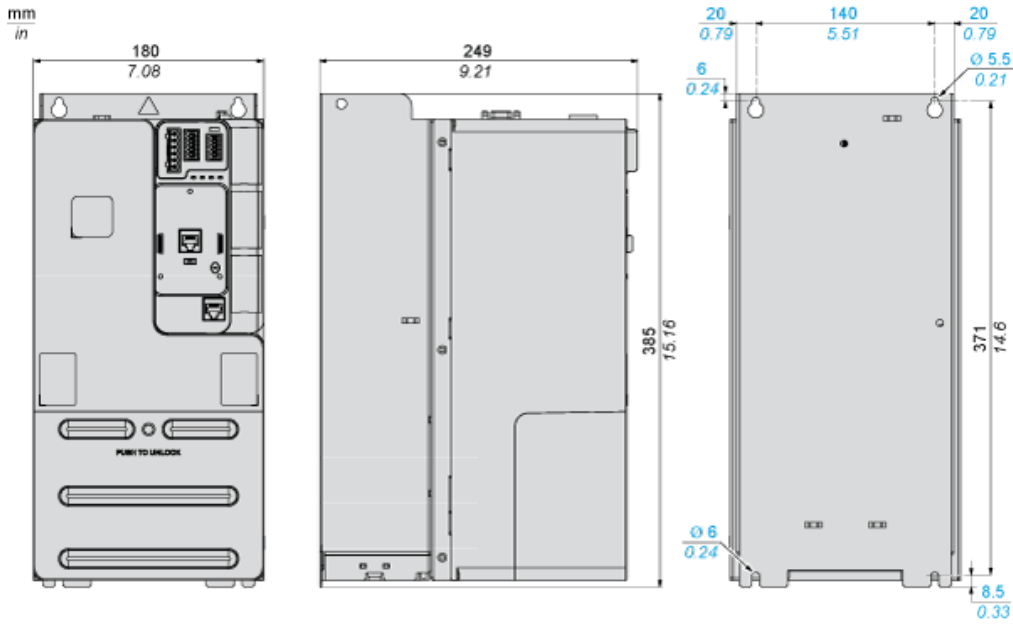

**Clearance**



**Dimensions in mm**

X1	X2	X3
≥ 100	≥ 100	≥ 60

**Dimensions in in.**

X1	X2	X3
≥ 3.94	≥ 3.94	≥ 2.36

**Mounting Types**

---

**Mounting Type A: Side by Side IP20**

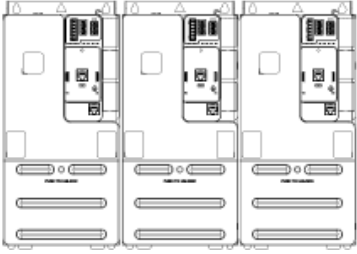

Possible, at ambient temperature  $\leq 50\text{ }^{\circ}\text{C}$  (122  $^{\circ}\text{F}$ )

**Mounting Type B: Individual IP20**

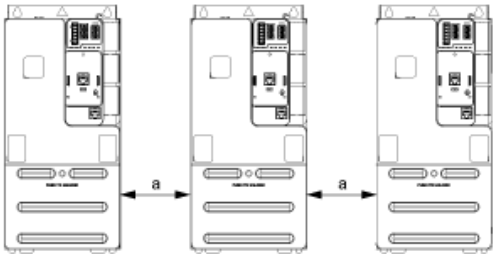

$a \geq 50\text{ mm}$  (1.97 in.) from 50...60 $^{\circ}\text{C}$ , no restriction below 50 $^{\circ}\text{C}$



**Connections and Schema**

**Three-phase Power Supply with Upstream Breaking via Line Contactor Without Safety Function STO**

Connection diagrams conforming to standards ISO13849 category 1 and IEC/EN 61508 capacity SIL1, stopping category 0 in accordance with standard IEC/EN 60204-1.

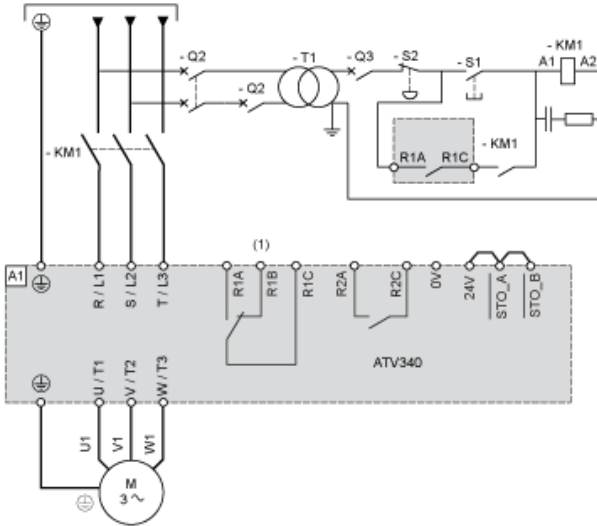

- (1) Use relay output R1 set to operating state Fault to switch Off the product once an error is detected.
- A1 : Drive
- KM1 : Line Contactor
- Q2, Q3 : Circuit breakers
- S1 : Pushbutton
- S2 : Emergency stop
- T1 : Transformer for control part

**Three-phase Power Supply With Downstream Breaking via Switch Disconnecter**

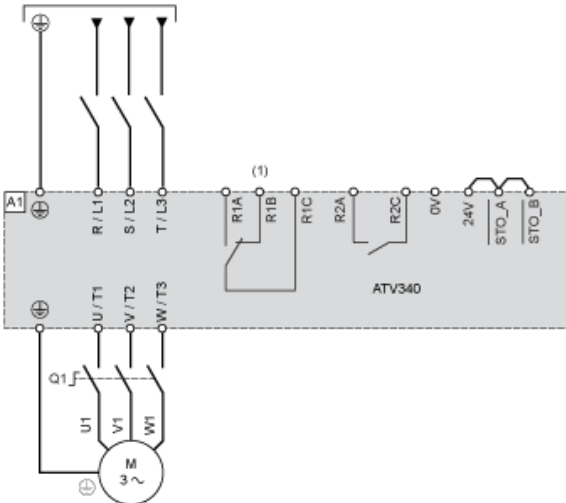

- (1) Use relay output R1 set to operating state Fault to switch Off the product once an error is detected.
- A1 : Drive
- Q1 : Switch disconnecter

**Sensor Connection**

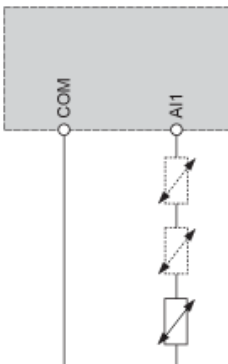

It is possible to connect either 1 or 3 sensors on terminals A11.

**Control Block Wiring Diagram**



- (1) 24V supply (STO)
  - (2) STO - Safe Torque Off
  - (3) PTI - Pulse Train In
  - (4) PTO - Pulse Train Out
  - (5) Motor Encoder connection
  - (6) Digital outputs
  - (7) Digital inputs
  - (8) Analog output
  - (9) Analog input
  - (10) Differential Analog Input
  - (11) Ethernet port (only on Ethernet drive version)
- SW1 : Sink/Source switch  
R1A, R1B, R1C : Relay  
R2A, R2C : Sequence relay

**Digital Inputs Wiring**

**Digital Inputs: Internal Supply**

Using DISUP Signal

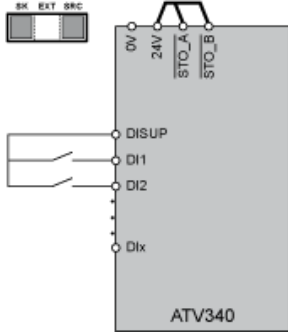

In SRC position DISUP outputs 24 V. In SK position DISUP is connected to 0 V.

**Digital Inputs: External Supply**

Positive Logic, Source, European Style

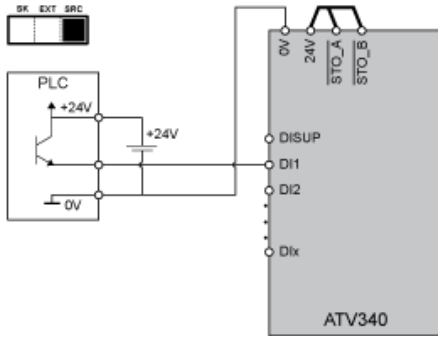

**Negative Logic, Sink, Asian Style**

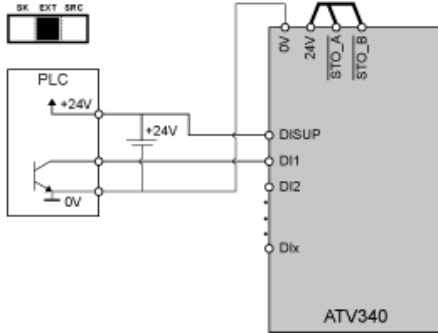

**Digital Inputs: Internal supply**

Negative Logic, Sink, Asian Style

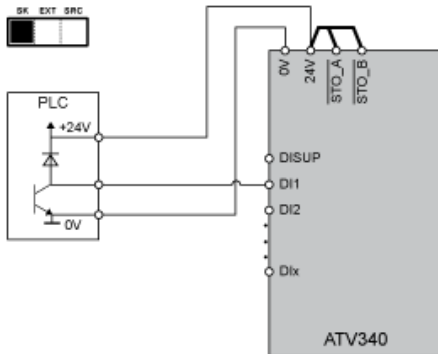

**Digital Outputs Wiring**

**Digital Outputs: Internal Supply**

Positive Logic, Source, European Style, DQCOM to +24V

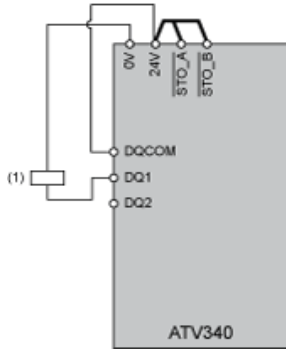

(1) Relay or valve

Negative Logic, Sink, Asian Style, DQCOM to 0V

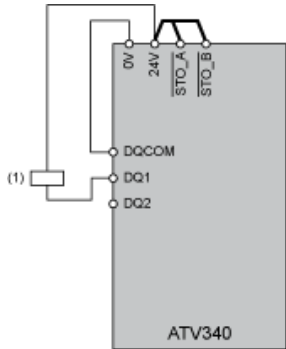

(1) Relay or valve

**Digital Outputs: External Supply**

Positive Logic, Source, European Style, DQCOM to +24V

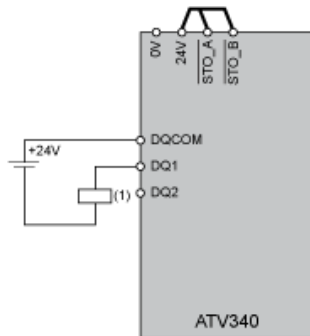

(1) Relay or valve

Negative Logic, Sink, Asian Style, DQCOM to 0V

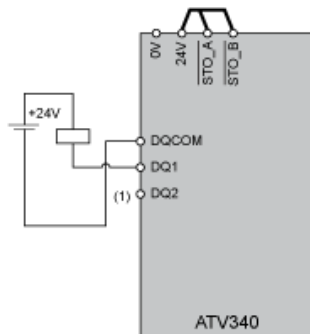

(1) Relay or valve

Open Loop Applications

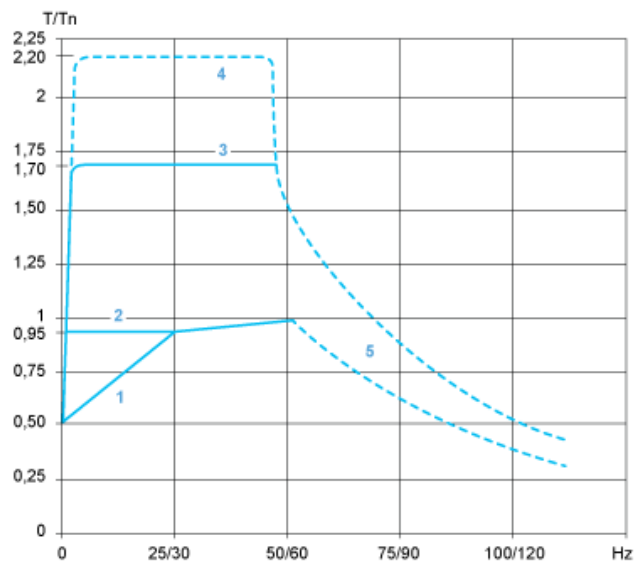

- 1 : Self-cooled motor: continuous useful torque
- 2 : Force-cooled motor: continuous useful torque
- 3 : Overtorque for 60 s maximum
- 4 : Transient overtorque for 2 s maximum
- 5 : Torque in overspeed at constant power

Closed Loop Applications



- 1 : Self-cooled motor: continuous useful torque
- 2 : Force-cooled motor: continuous useful torque
- 3 : Overtorque for 60 s maximum
- 4 : Transient overtorque for 2 s maximum
- 5 : Torque in overspeed at constant power

Recommended replacement(s)