



Betriebsanleitung Instruções de Serviço	Operating Instructions İşletme kılavuzu	Instructions de service Инструкция по эксплуатации	Instructivo 使用说明	Istruzioni operative
--	--	---	---------------------	----------------------

	Deutsch	English	Français
	Vor der Installation, dem Betrieb oder der Wartung des Geräts muss diese Anleitung gelesen und verstanden werden.	Read and understand these instructions before installing, operating, or maintaining the equipment.	Ne pas installer, utiliser ou intervenir sur cet équipement avant d'avoir lu et assimilé les présentes instructions et notamment les conseils de sécurité et mises en garde qui y figurent.
	⚠ GEFÄHR	⚠ DANGER	⚠ DANGER
	Gefährliche Spannung. Lebensgefahr oder schwere Verletzungsgefahr. Vor Beginn der Arbeiten Anlage und Gerät spannungsfrei schalten.	Hazardous voltage. Will cause death or serious injury. Turn off and lock out all power supplying this device before working on this device.	Tension électrique. Danger de mort ou risque de blessures graves. Mettre hors tension avant d'intervenir sur l'appareil.
	VORSICHT	CAUTION	PRUDENCE
	Eine sichere Gerätefunktion ist nur mit zertifizierten Komponenten gewährleistet!	Reliable functioning of the equipment is only ensured with certified components.	La sécurité de fonctionnement de l'appareil n'est garantie qu'avec des composants certifiés.
	Español	Italiano	Português
	Leer y comprender este instructivo antes de la instalación, operación o mantenimiento del equipo.	Leggere con attenzione queste istruzioni prima di installare, utilizzare o eseguire manutenzione su questa apparecchiatura.	Ler e compreender estas instruções antes da instalação, operação ou manutenção do equipamento.
	⚠ PELIGRO	⚠ PERICOLO	⚠ PERIGO
	Tensión peligrosa. Puede causar la muerte o lesiones graves. Desconectar la alimentación eléctrica antes de trabajar en el equipo.	Tensione pericolosa. Può provocare morte o lesioni gravi. Scogliere l'alimentazione prima di eseguire interventi sull'apparecchiatura.	Tensão perigosa. Perigo de morte ou ferimentos graves. Desligue a alimentação elétrica e proteja contra o religamento, antes de iniciar o trabalho no equipamento
	PRECAUCIÓN	CAUTELA	CUIDADO
	El funcionamiento seguro del aparato sólo está garantizado con componentes certificados.	Il funzionamento sicuro dell'apparecchiatura è garantito soltanto con componenti certificati.	O funcionamento seguro do aparelho apenas pode ser garantido se forem utilizados os componentes certificados.
	Türkçe	Русский	中文
	Cihazın kurulumundan, çalıştırılmasından veya bakıma tabi tutulmasından önce, bu kılavuz okunmuş ve anlaşılmış olmalıdır.	Перед установкой, вводом в эксплуатацию или обслуживанием устройства необходимо прочесть и понять данное руководство.	安装、使用和维修本设备前必须先阅读并理解本说明。
	⚠ TEHLİKE	⚠ ОПАСНО	⚠ 危險
	Tehlikeli gerilim. Ölüm tehlikesi veya ağır yaralanma tehlikesi mevcuttur. Çalışmalara başlamadan önce, sistemin ve cihazın enerjisini kesiniz.	Опасное напряжение. Опасность для жизни или возможность тяжелых травм. Перед началом работ отключить подачу питания к установке и к устройству.	危險电压。可能导致生命危险或重伤危险。 操作设备时必须确保切断电源。
	ÖNEMLİ DİKKAT	ОСТОРОЖНО	警告
	Cihazın güvenli çalışması ancak sertifikalı bileşenler kullanılması halinde garanti edilebilir.	Безопасность работы устройства гарантировано только при использовании сертифицированных компонентов.	只有使用经过认证的部件才能保证设备的正常运转！

Technical Support (<https://www.siemens.com/support-request>)

DE: Montage	EN: Installation	FR: Montage	3LD20..	3LD21../22..	3LD25..	3LD27../28..	3LD23../24..
Anschlusschrauben Schalter: Anzugsmoment:	Terminal screws switches: Tightening torque:	Vis de raccordement interrupteur : Couple de serrage :	M3,5 150 ... 200 Ncm	M4 200 ... 250 Ncm	M6 250 ... 300 Ncm	M6 250 ... 300 Ncm	M12 950 ... 1000 Ncm
Anschlussquerschnitt ein- und mehrdrähtig: feindrähtig mit Aderendhülsen max.: / AWG:	Connecting cross solid and stranded wire: Flexible cable with ferrule max.: / AWG:	Section des conducteurs uni- ou multifilaires : Âme souple avec embout max.: / AWG :	1,5 ... 6 mm ² 4 mm ² / 18 ... 10	1,5 ... 16 mm ² 10 mm ² / 14 ... 8	2,5 ... 35 mm ² 16 mm ² / 14 ... 6	4 ... 50 mm ² 35 mm ² / 12 ... 1	10 ... 185 mm ² 185 mm ² / 1 ... MCM 400
Befestigungsschrauben (Vierloch): Anzugsmoment:	Fastening screws (Four-hole): Tightening torque:	Vis de fixation (à 4 trous): Couple de serrage :	4,8 x 16 100 ... 130 Ncm	4,8 x 16 100 ... 130 Ncm	4,8 x 16 100 ... 130 Ncm	4,8 x 16 100 ... 130 Ncm	M5 200 ... 250 Ncm
Plastikmutter (Zentralloch): Anzugsmoment:	Plastic nut (central mounting): Tightening torque:	Ecrou plastique (perçage au centre): Couple de serrage :	M22 x 1,5 200 ... 250 Ncm	M22 x 1,5 200 ... 250 Ncm	M22 x 1,5 200 ... 250 Ncm	M22 x 1,5 200 ... 250 Ncm	—
Anschlusschrauben Hilfsschalter: Anzugsmoment:	Terminal screws aux. switches: Tightening torque:	Vis de raccordement sur bloc de contacts aux.: Couple de serrage :	M3,5 80 ... 100 Ncm	M3,5 80 ... 100 Ncm	M3,5 80 ... 100 Ncm	M3,5 80 ... 100 Ncm	M3,5 80 ... 100 Ncm
Anschlussquerschnitt Hilfsschalter ein- und mehrdrähtig: feindrähtig mit Aderendhülsen max.: / AWG:	Connecting cross aux. switches solid and stranded wire: Flexible cable with ferrule max.: / AWG:	Section des conducteurs bloc de contacts aux. uni- ou multifilaires : Âme souple avec embout max.: / AWG :	0,75 ... 2,5 mm ² 2,5 mm ² / 14 ... 12	0,75 ... 2,5 mm ² 2,5 mm ² / 14 ... 12	0,75 ... 2,5 mm ² 2,5 mm ² / 14 ... 12	0,75 ... 2,5 mm ² 2,5 mm ² / 14 ... 12	0,75 ... 2,5 mm ² 2,5 mm ² / 14 ... 12
Griffschraube: Anzugsmoment:	Handle screw: Tightening torque:	Manette: Couple de serrage :	2,9 x 13 180 ... 230 Ncm	2,9 x 13 180 ... 230 Ncm	2,9 x 13 200 ... 250 Ncm	2,9 x 13 200 ... 250 Ncm	3,5 x 13 200 ... 250 Ncm
ES: Montaje	IT: Montaggio	PT: Montagem	3LD20..	3LD21../22..	3LD25..	3LD27../28..	3LD23../24..
Tornillos de conexión interruptor: Par de apriete:	Viti di serraggio interruttori: Coppia di serraggio:	Parafusos de conexão da chave: Torque de aperto:	M3,5 150 ... 200 Ncm	M4 200 ... 250 Ncm	M6 250 ... 300 Ncm	M6 250 ... 300 Ncm	M12 950 ... 1000 Ncm
Sección de conexión unifilar o multifilar: Cable flexible con manguito max.: / AWG:	Sezione di collegamento unifilare e multifilare: Filo flessibile con puntalini preisolati max.: / AWG:	Seção transversal de conexão unifilar e multifilar: Cabo flexível com terminais de fio max.: / AWG:	1,5 ... 6 mm ² 4 mm ² / 18 ... 10	1,5 ... 16 mm ² 10 mm ² / 14 ... 8	2,5 ... 35 mm ² 16 mm ² / 14 ... 6	4 ... 50 mm ² 35 mm ² / 12 ... 1	10 ... 185 mm ² 185 mm ² / 1 ... MCM 400
Tornillos de fijación (4 oficinas): Par de apriete:	Viti di fissaggio (quattro fon): Coppia di serraggio:	Parafusos de fixação (quatro furos): Torque de aperto:	4,8 x 16 100 ... 130 Ncm	4,8 x 16 100 ... 130 Ncm	4,8 x 16 100 ... 130 Ncm	4,8 x 16 100 ... 130 Ncm	M5 200 ... 250 Ncm
Tuerca de plástico (orificio central): Par de apriete:	Dado in plastica (foro centrale): Coppia di serraggio:	Porca de plástico (furo central): Torque de aperto:	M22 x 1,5 200 ... 250 Ncm	M22 x 1,5 200 ... 250 Ncm	M22 x 1,5 200 ... 250 Ncm	M22 x 1,5 200 ... 250 Ncm	—
Tornillos de conexión interruptor auxiliar: Par de apriete:	Viti di serraggio interruttori ausiliari: Coppia di serraggio:	Parafusos de conexão da chave auxiliar: Torque de aperto:	M3,5 80 ... 100 Ncm	M3,5 80 ... 100 Ncm	M3,5 80 ... 100 Ncm	M3,5 80 ... 100 Ncm	M3,5 80 ... 100 Ncm
Tornillos de conexión interruptor auxiliar unifilar o multifilar: Cable flexible con manguito max.: / AWG:	Viti di serraggio interruttori ausiliari unifilare e multifilare: Filo flessibile con puntalini preisolati max.: / AWG:	Parafusos de conexão da chave auxiliar unifilar e multifilar: Cabo flexível com terminais de fio max.: / AWG:	0,75 ... 2,5 mm ² 2,5 mm ² 14 ... 12	0,75 ... 2,5 mm ² 2,5 mm ² 14 ... 12	0,75 ... 2,5 mm ² 2,5 mm ² 14 ... 12	0,75 ... 2,5 mm ² 2,5 mm ² 14 ... 12	0,75 ... 2,5 mm ² 2,5 mm ² 14 ... 12
Tornillo de empufadura: Par de apriete:	Vite a manopola: Coppia di serraggio:	Parafuso de ajuste manual: Torque de aperto:	2,9 x 13 180 ... 230 Ncm	2,9 x 13 180 ... 230 Ncm	3,5 x 13 200 ... 250 Ncm	3,5 x 13 200 ... 250 Ncm	3,5 x 13 200 ... 250 Ncm
TR: Montaj	PY: Монтаж	中文：安装	3LD20..	3LD21../22..	3LD25..	3LD27../28..	3LD23../24..
Şalter bağlantı vidaları: Sıkıştırma momenti:	Болты, выключатель: Момент затяжки:	连接螺栓用于开关: 拧紧力矩:	M3,5 150 ... 200 Ncm	M4 200 ... 250 Ncm	M6 250 ... 300 Ncm	M6 250 ... 300 Ncm	M12 950 ... 1000 Ncm
Bağlantı kesiti, tek ve çok telli: Kablo bitim başlığıyla ince telli azami: AWG:	Сечение соединительного кабеля одно- и многожильный: Тонкожильный с кабельными зажимами макс. Расстояние между жилами:	连接端横截面单股线的和多股线的: 带有接线套筒的细导线, 最大为: AWG:	1,5 ... 6 mm ² 4 mm ² 18 ... 10	1,5 ... 16 mm ² 10 mm ² 14 ... 8	2,5 ... 35 mm ² 16 mm ² 14 ... 6	4 ... 50 mm ² 35 mm ² 12 ... 1	10 ... 185 mm ² 185 mm ² 1 ... MCM 400
Sabitleme vidası (dört delik): Sıkıştırma momenti:	Крепящие болты (по четырем отверстиям): Момент затяжки:	固定螺栓 (四孔): 拧紧力矩:	4,8 x 16 100 ... 130 Ncm	4,8 x 16 100 ... 130 Ncm	4,8 x 16 100 ... 130 Ncm	4,8 x 16 100 ... 130 Ncm	M5 200 ... 250 Ncm
Yardımcı şalter bağlantı vidaları: Sıkıştırma momenti:	Пластмассовая гайка (центральное отверстие): Момент затяжки:	塑料螺母 (中心钻孔): 拧紧力矩:	M22 x 1,5 200 ... 250 Ncm	M22 x 1,5 200 ... 250 Ncm	M22 x 1,5 200 ... 250 Ncm	M22 x 1,5 200 ... 250 Ncm	—
Yardımcı şalter bağlantı vidaları: Sıkıştırma momenti:	Болты, дополнительный выключатель: Момент затяжки:	连接螺栓用于辅助开关: 拧紧力矩:	M3,5 80 ... 100 Ncm	M3,5 80 ... 100 Ncm	M3,5 80 ... 100 Ncm	M3,5 80 ... 100 Ncm	M3,5 80 ... 100 Ncm
Bağlantı kesiti yardımcı şalter tek ve çok telli: Kablo bitim başlığıyla ince telli azami: AWG:	Сечение соединительного кабеля дополнителный выключатель одно- и многожильный: Тонкожильный с кабельными зажимами макс. Расстояние между жилами:	连接端横截面辅助开关单股线的和多股线的: 带有接线套筒的细导线, 最大为: AWG:	0,75 ... 2,5 mm ² 2,5 mm ² 14 ... 12	0,75 ... 2,5 mm ² 2,5 mm ² 14 ... 12	0,75 ... 2,5 mm ² 2,5 mm ² 14 ... 12	0,75 ... 2,5 mm ² 2,5 mm ² 14 ... 12	0,75 ... 2,5 mm ² 2,5 mm ² 14 ... 12
Çevirmeli vida: Sıkıştırma momenti:	Винт с рукояткой: Момент затяжки:	滚花头螺杆: 拧紧力矩:	2,9 x 13 180 ... 230 Ncm	2,9 x 13 180 ... 230 Ncm	3,5 x 13 200 ... 250 Ncm	3,5 x 13 200 ... 250 Ncm	3,5 x 13 200 ... 250 Ncm

3LD2022

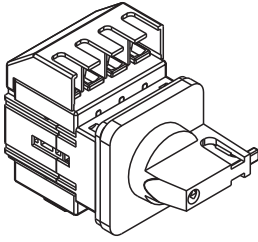

3LD2122
3LD2222

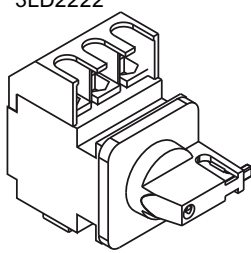

3LD2003

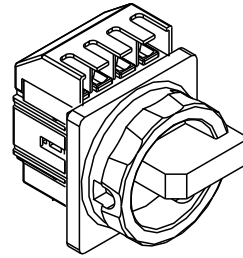

3LD2103 3LD2504
3LD2203 3LD2704
3LD2804

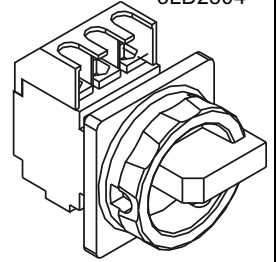

3LD2050

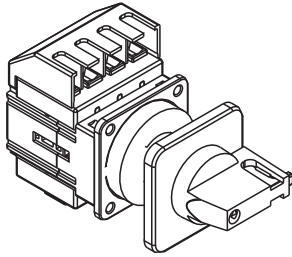

3LD2150 3LD2250

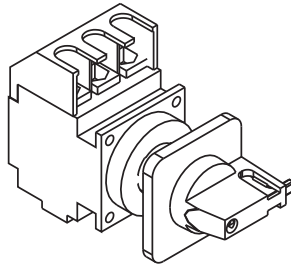

3LD2054

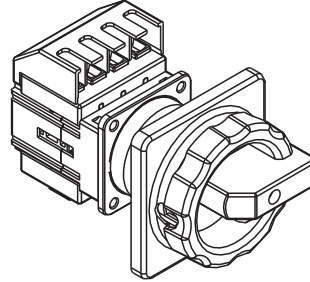

3LD2154 3LD2254
3LD2555

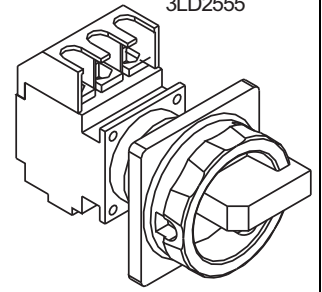

3LD2013
3LD2015

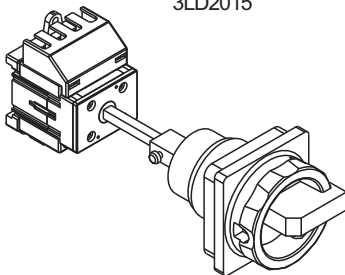

3LD2113 3LD2514
3LD2115 3LD2516
3LD2213 3LD2714
3LD2215 3LD2716
3LD2814
3LD2816

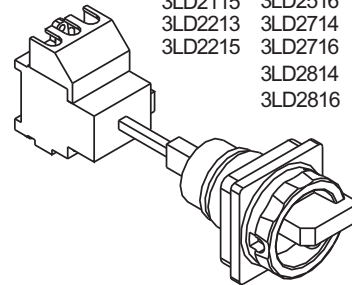

3LD2044
3LD2048

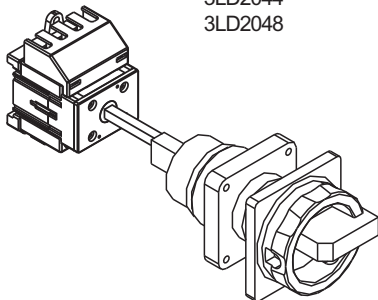

3LD2144 3LD2544
3LD2148 3LD2545
3LD2244 3LD2548
3LD2248 3LD2744
3LD2748
3LD2848

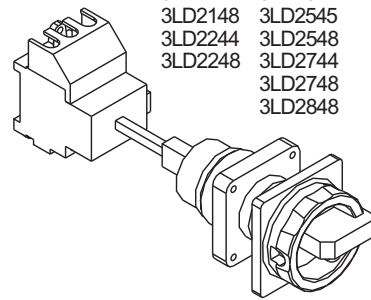

3LD2030

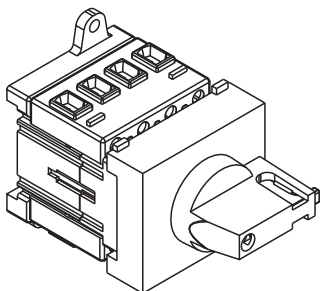

3LD2130
3LD2230

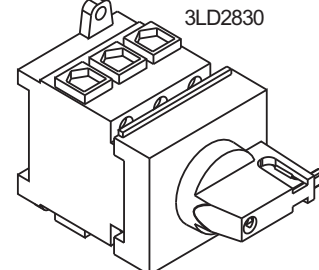

3LD2530
3LD2730
3LD2830

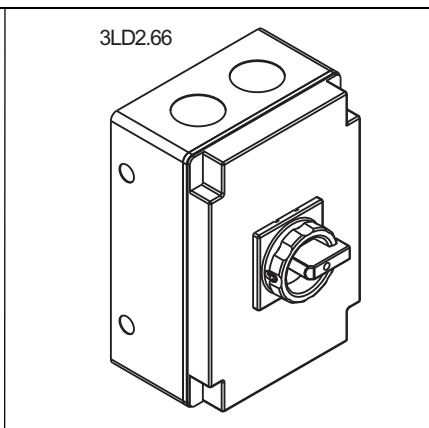
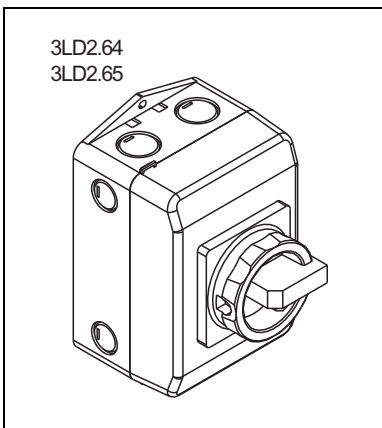
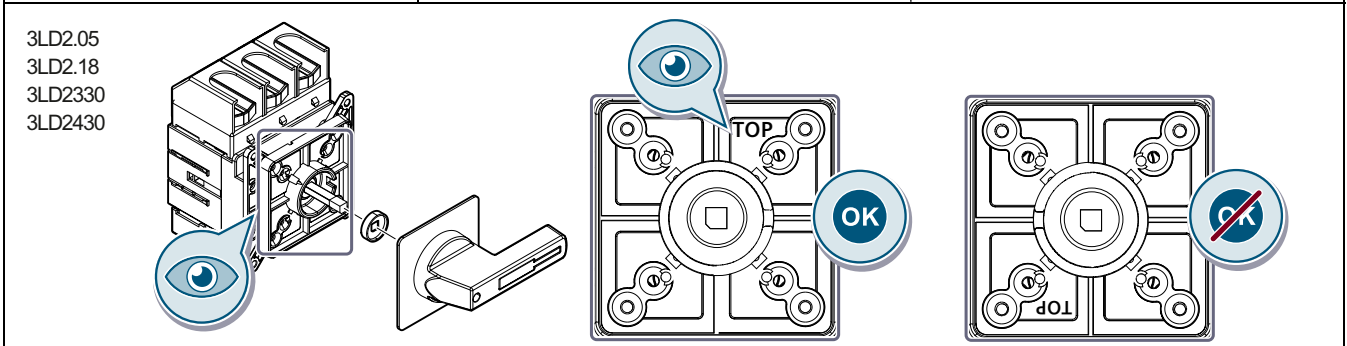
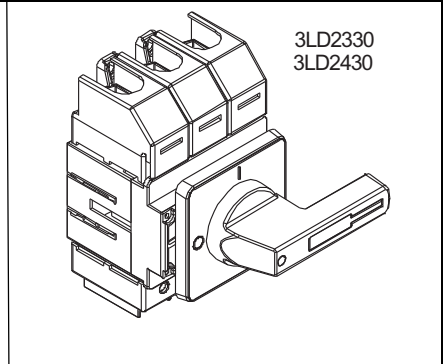
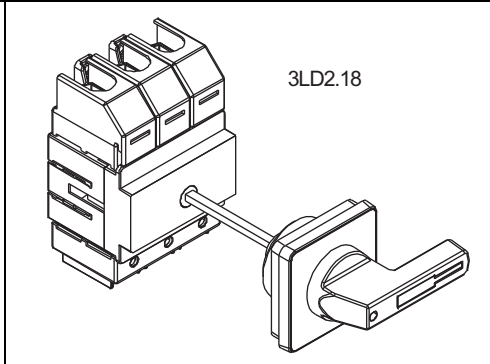
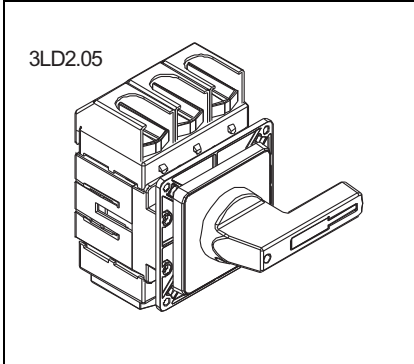
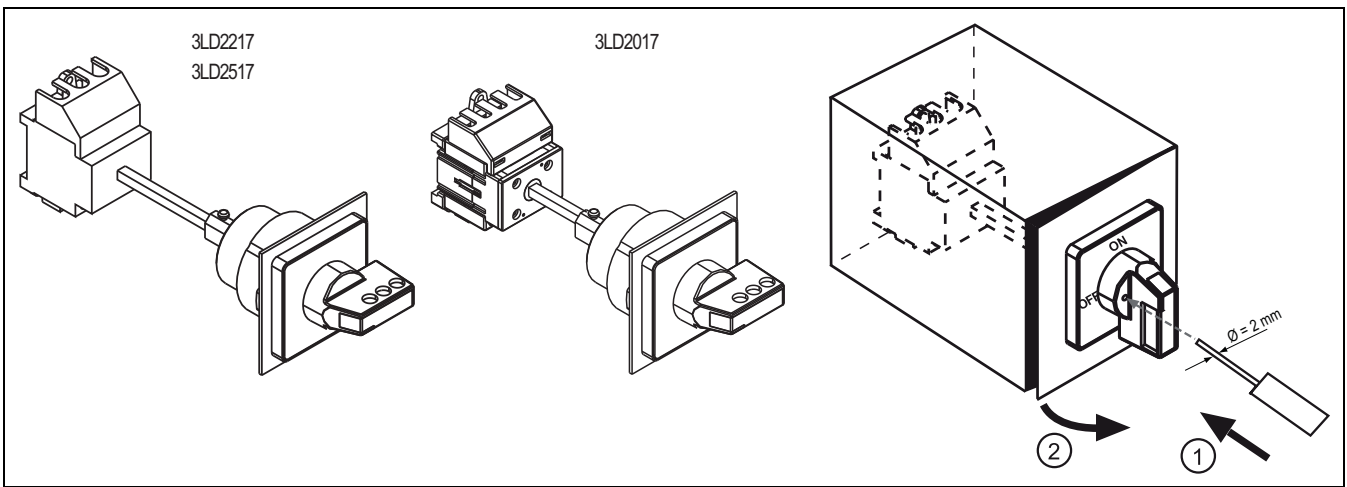

	l [mm]
3LD20 + N / PE	8,5
3LD21.. / 3LD22.. + N / PE	9,5
3LD23.. / 3LD24.. + N / PE	15,0
3LD25.. + N / PE	13,5
3LD27.. / 3LD28.. + N / PE	13,5 ...15,0
3LD9200	8,0

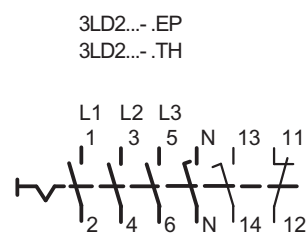
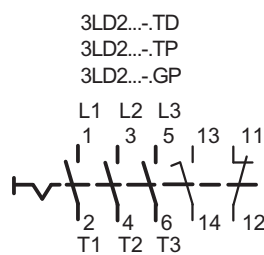
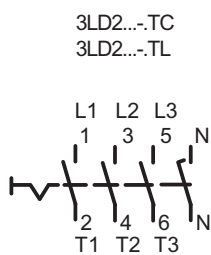
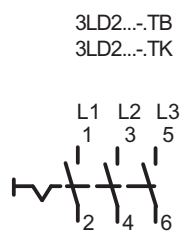

3LD2.54 3LD2555

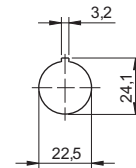
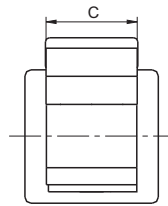
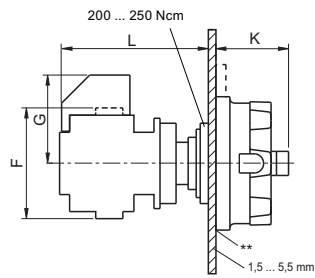
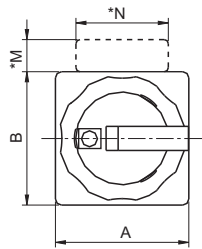

Bohrbild / Drilling pattern / Plan de perçage / esquema de talandros / schema di foratura / esquema de furação / Delik resmi / Расположение отверстий / 钻孔图

3LD2.03 3LD2.04

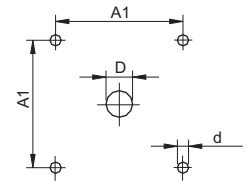
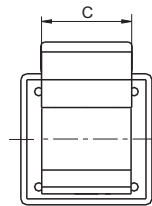
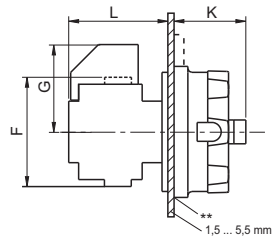
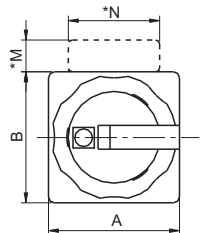

Bohrbild / Drilling pattern / Plan de perçage / esquema de talandros / schema di foratura / esquema de furação / Delik resmi / Расположение отверстий / 钻孔图

3LD2.50

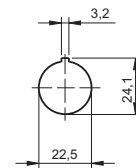
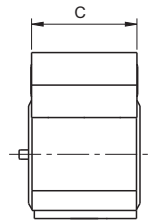
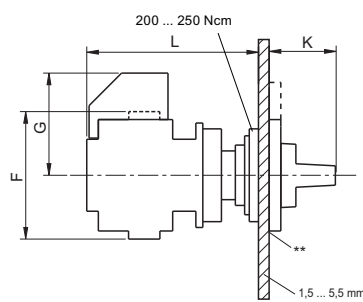
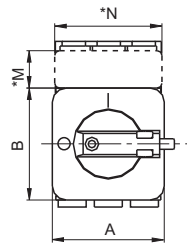

Bohrbild / Drilling pattern / Plan de perçage / esquema de talandros / schema di foratura / esquema de furação / Delik resmi / Расположение отверстий / 钻孔图

3LD2.22

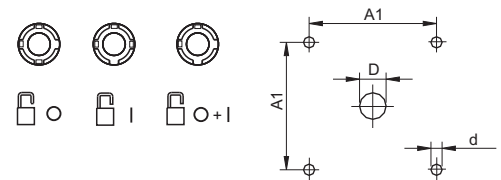
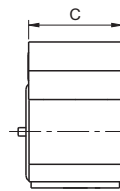
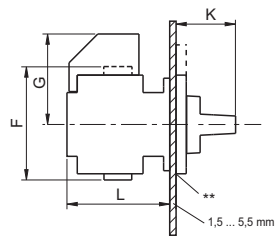
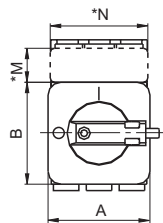

Bohrbild / Drilling pattern / Plan de perçage / esquema de talandros / schema di foratura / esquema de furação / Delik resmi / Расположение отверстий / 钻孔图

3LD2.05

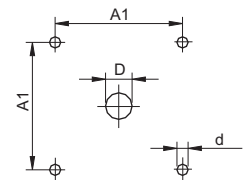
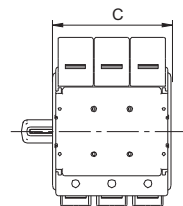
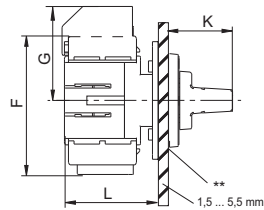
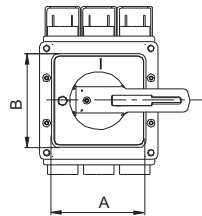

Bohrbild / Drilling pattern / Plan de perçage / esquema de talandros / schema di foratura / esquema de furação / Delik resmi / Расположение отверстий / 钻孔图

Type	A	B	A1	C	D	d	F	G	K	L	*M	*N
3LD2003	67	67	48	48	10	5,0	50	38	37	50	17	47
3LD2022	49	49	36	48	10	5,0	50	38	30	50	17	47
3LD2050	49	49	—	48	—	—	50	38	30	74	17	47
3LD2054	67	67	—	48	—	—	50	38	37	74	17	47
3LD2.55	90	90	—	60	—	—	64	50	46	81	17	47
3LD2103 / 3LD2203	67	67	48	46	10	5,0	55	44	37	50	17	47
3LD2122 / 3LD2222	49	49	36	46	10	5,0	55	44	30	50	17	47
3LD2150 / 3LD2250	49	49	—	46	—	—	55	44	30	74	17	47
3LD2154 / 3LD2254	67	67	—	46	—	—	55	44	37	74	17	47
3LD2305 / 3LD2405	94	94	68	112	13	5,5	148	95	67	94	17	47
3LD2504	90	90	48	60	10	5,0	64	50	46	59	17	47
3LD2704 / 3LD2804	90	90	48	71	10	5,0	83	54	46	61	17	47

* / ** : siehe Seite 8 / see page 8 / voir page 8 / vea pag. 8 / vedi pag. 8 / veja pag. 8 / Bkz. Sayfa 8 / См. страницу 8 / 参见第 8 页 .

3LD2.13

3LD2.14

3LD2.15⁽¹⁾

3LD2.16⁽¹⁾

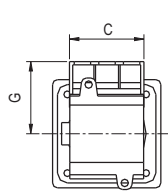
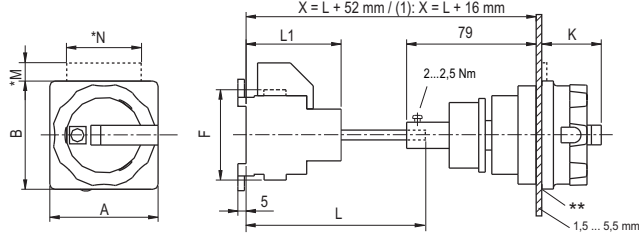

Tür / Door / Porte / Puerta / Porta / Porta / Капи / Дверь / 门

Boden / Base / Plancher / Base / Pavimento / Fundo / Zemin / Пон / 底

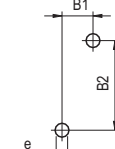
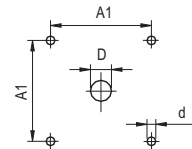

Bohrbild / Drilling pattern / Plan de perçage / esquema de talandros / schema di foratura / esquema de furação / Delik resmi / Расположение отверстий / 钻孔图

3LD2.44

3LD2.45

3LD2.48⁽²⁾

200 ... 250 Ncm

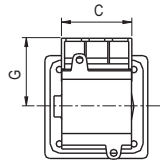
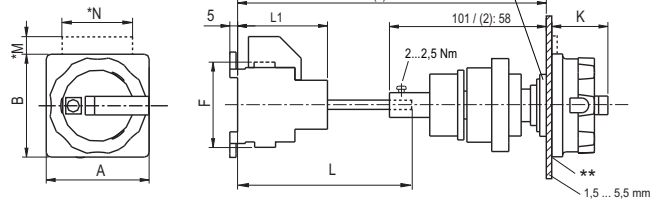

Tür / Door / Porte / Puerta / Porta / Porta / Капи / Дверь / 门

Boden / Base / Plancher / Base / Pavimento / Fundo / Zemin / Пон / 底

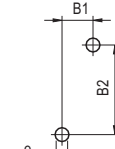
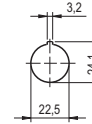

Bohrbild / Drilling pattern / Plan de perçage / esquema de talandros / schema di foratura / esquema de furação / Delik resmi / Расположение отверстий / 钻孔图

3LD2.17

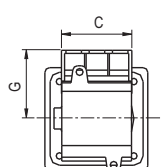
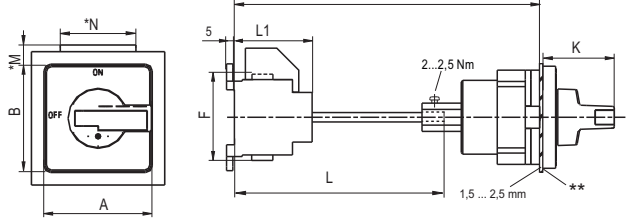

Tür / Door / Porte / Puerta / Porta / Porta / Капи / Дверь / 门

Boden / Base / Plancher / Base / Pavimento / Fundo / Zemin / Пон / 底

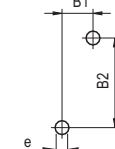
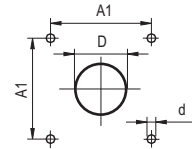

Bohrbild / Drilling pattern / Plan de perçage / esquema de talandros / schema di foratura / esquema de furação / Delik resmi / Расположение отверстий / 钻孔图

3LD2.18

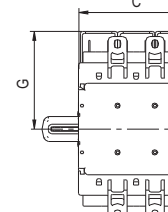
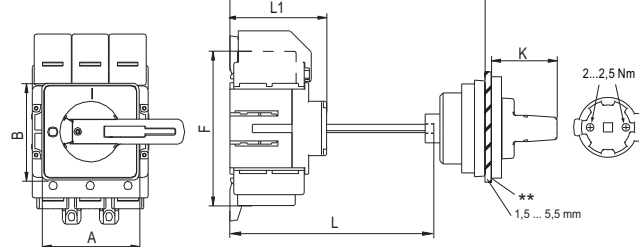

Tür / Door / Porte / Puerta / Porta / Porta / Капи / Дверь / 门

Boden / Base / Plancher / Base / Pavimento / Fundo / Zemin / Пон / 底

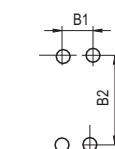
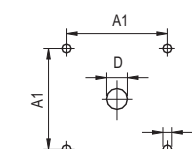

Bohrbild / Drilling pattern / Plan de perçage / esquema de talandros / schema di foratura / esquema de furação / Delik resmi / Расположение отверстий / 钻孔图

Type	A	B	A1	B1	B2	C	D	d	e	F	G	K	L	L1	Xmin	*M	*N
3LD2013	67	67	48	22	60	48	10	5,0	4,5	50	38	37	330	58	138	17	47
3LD2015	67	67	48	22	60	48	10	5,0	4,5	50	38	37	330	58	95	17	47
3LD2017	65	65	48	22	60	48	30	5,0	4,5	50	38	37	330	58	138	17	47
3LD2044	67	67	—	22	60	48	—	—	4,5	50	38	37	330	58	160	17	47
3LD2048	67	67	—	22	60	48	—	—	4,5	50	38	37	330	58	107	17	47
3LD2113 / 3LD2213	67	67	48	22	60	46	10	5,0	4,5	55	44	37	330	58	138	17	47
3LD2115 / 3LD2215	67	67	48	22	60	46	10	5,0	4,5	55	44	37	330	58	95	17	47
3LD2144 / 3LD2244	67	67	—	22	60	46	—	—	4,5	55	44	37	330	58	160	17	47
3LD2148 / 3LD2248	67	67	—	22	60	46	—	—	4,5	55	44	37	330	58	107	17	47
3LD2217	65	65	48	22	60	46	30	5,0	4,5	55	44	37	330	58	138	17	47
3LD2318 / 3LD2418	94	94	68	36	164	112	13	5,5	6,3	148	95	67	574	104	153	17	47
3LD2514	90	90	48	25	70	60	10	5,5	5,5	64	50	46	338	68	148	17	47
3LD2516	90	90	48	25	70	60	10	5,5	5,5	64	50	46	338	68	105	17	47
3LD2517	65	65	48	25	70	60	30	5,5	5,5	64	50	45	338	68	148	17	47
3LD2544	67	67	—	25	70	60	—	—	5,5	64	50	46	338	68	170	17	47
3LD2545	90	90	—	25	70	60	—	—	5,5	64	50	46	338	68	170	17	47
3LD2548	67	67	—	25	70	60	10	5,5	5,5	64	50	37	338	68	117	17	47
3LD2714 / 3LD2814	90	90	48	25	90	71	10	5,5	5,5	83	54	46	340	70	150	17	47
3LD2716 / 3LD2816	90	90	48	25	90	71	10	5,5	5,5	83	54	46	340	70	107	17	47
3LD2744	67	67	—	25	90	71	—	—	5,5	83	54	46	340	70	170	17	47
3LD2748 / 3LD2848	67	67	—	25	90	71	10	5,5	5,5	83	54	46	340	70	117	17	47

* / ** : siehe Seite 8 / see page 8 / voir page 8 / vea pág. 8 / vedi pag. 8 / veja pág. 8 / Bkz. Sayfa 8 / См. страницу 8 / 参见第 8 页 .

3LD2330 / 3LD2430

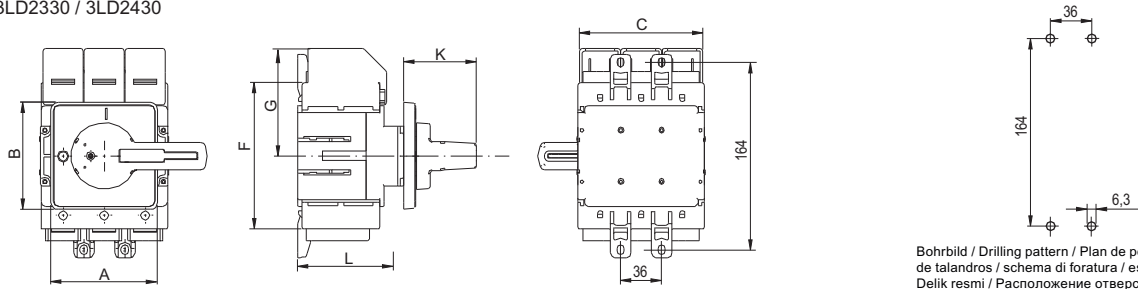

Bohrbild / Drilling pattern / Plan de perçage / esquema de talandros / schema di foratura / esquema de furação / Delik resmi / Расположение отверстий / 钻孔图

3LD2.30

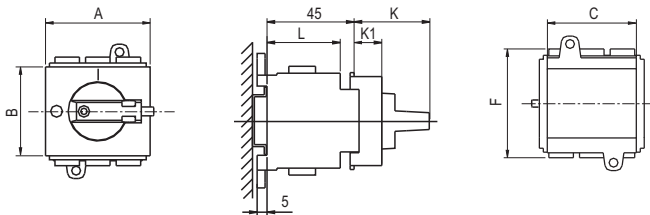

Type	A	B	C	F	K	K1	L
3LD2030	53	45	48	50	40	14	37
3LD2130	53	45	46	55	40	14	37
3LD2230	53	45	46	55	40	14	37
3LD2530	64	45	60	64	44	16	44
3LD2730	71	45	71	83	47	19	44
3LD2830	71	45	71	83	47	19	44

3LD2.64

3LD2.65

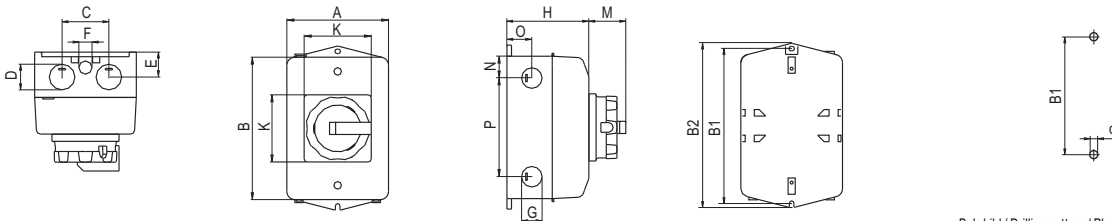

Bohrbild / Drilling pattern / Plan de perçage / esquema de talandros / schema di foratura / esquema de furação / Delik resmi / Расположение отверстий / 钻孔图

3LD2.66

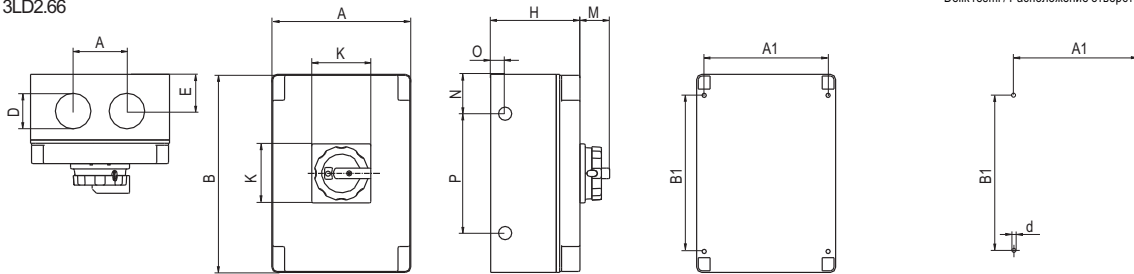

DE	Anzugsmoment Deckelschraube Isokapselung 3LD2.64..3LD2.65..	100...130 Ncm	⊕ PZ1
EN	Tightening torque lid screw for plastic enclosure 3LD2.64..3LD2.65..	100...130 Ncm	⊕ PZ1
FR	Couple de serrage vis du couvercle boîtier d'isolement 3LD2.64..3LD2.65..	100...130 Ncm	⊕ PZ1
ES	Par de apriete del tornillo de la tapa del encapsulamiento de plástico 3LD2.64..3LD2.65..	100...130 Ncm	⊕ PZ1
IT	Coppia di serraggio vite coperchio incapsulatura isolante 3LD2.64..3LD2.65..	100...130 Ncm	⊕ PZ1
PT	Torque de aperto do parafuso da tampa e encapsulamento de plástico 3LD2.64..3LD2.65..	100...130 Ncm	⊕ PZ1
TR	3LD2.64..3LD2.65.. Iso kapsülleme başlıklı vidası sıkıştırma momenti	100...130 Ncm	⊕ PZ1
PY	Момент затяжки, болт крышки, изолирующее корпусирование 3LD2.64..3LD2.65..	100...130 Ncm	⊕ PZ1
中文	拧紧力矩顶盖螺栓封闭外罩 3LD2.64..3LD2.65..	100...130 Ncm	⊕ PZ1

Type	A	B	A1	B1	B2	C	d	D	E	F	G	H	K	M	N	O	P
3LD2.64	100	140	—	152	164	46	4,5	4 x M25	24	—	4 x M20	81	67	36	22	24	97
3LD2.65	146	176	—	188	200	66	4,5	4 x M32/40	37	—	4 x M20	104	90	45	40	30	95
3LD2.66	212	302	189	238	-	84	6,5	4 x M50/63	57	2 x M20	4 x M20	136	90	45	60	22	182
3LD2.64-0US2	3,94"	5,51"	—	5,99"	164	1,81"	0,26"	4 x 1/2" / 3/4"	0,94"	—	4 x M20	3,19"	2,64"	1,42"	0,87"	0,94"	3,82"
3LD2.65-0US2	5,75"	6,93"	—	7,40"	200	2,60"	0,26"	4 x 3/4" / 1"	1,46"	—	4 x M20	4,09"	3,54"	1,77"	1,57"	1,18"	3,74"
3LD2.66-0US2	8,35"	11,89"	7,44"	9,37"	—	3,31"	0,26"	4 x 1" / 1 1/4"	2,24"	2 x M20	4 x M20	5,35"	3,54"	1,77"	2,36"	0,87"	7,17"

DE	* Zusatzfrontschild siehe Zubehörteile	** Dichtungsplatte hinter Sichtblende, Lage der Wellendichtung beachten.
EN	* Additional front plate see accessories	** Sealing plate behind the front panel must align with handle mounting holes.
FR	* Pour plastron supplém. voir accessoires	** Plaque d'étanchéité derrière le cache, respecter la position du joint d'arbre.
ES	* Placa frontal adicional, ver accesorios	** Placa de sellado detrás de la placa frontal, respetar posición de la obturación del eje.
IT	* Etichetta frontale aggiuntiva vedi accessori	** Pannello di tenuta dietro diaframma, osservare la posizione della guarnizione per alberi.
PT	* Placa frontal adicional ver acessórios	** Placa de vedação atrás do painel frontal, observar a posição da vedação de eixo.
TR	* İlave ön levha Bkz. Aksesuarlar	** Conta plaka diyafram arkasında, mil contasının pozisyonuna dikkat ediniz.
PY	* Дополнительная фронтальная пластина, смотри комплектующие детали	** Уплотнительная пластина за фронтальной пластиной, необходимо учитывать положение сальника.
中文	* 附加正面标牌参见附件部分	** 密封片位于挡板之后, 注意轴密封的位置。

① 3LD92.0-0B	② 3LD92.0-2B	③ 3LD92.0-5B
--------------	--------------	--------------

(1)

	A	B
3LD9200 - 2.	13	50
3LD9200 - 5.	11	50,5
3LD9220 - ...	16	55
3LD9250 - ...	20	64
3LD9280 - ...	23	83
3LD9240-...	36,5	149

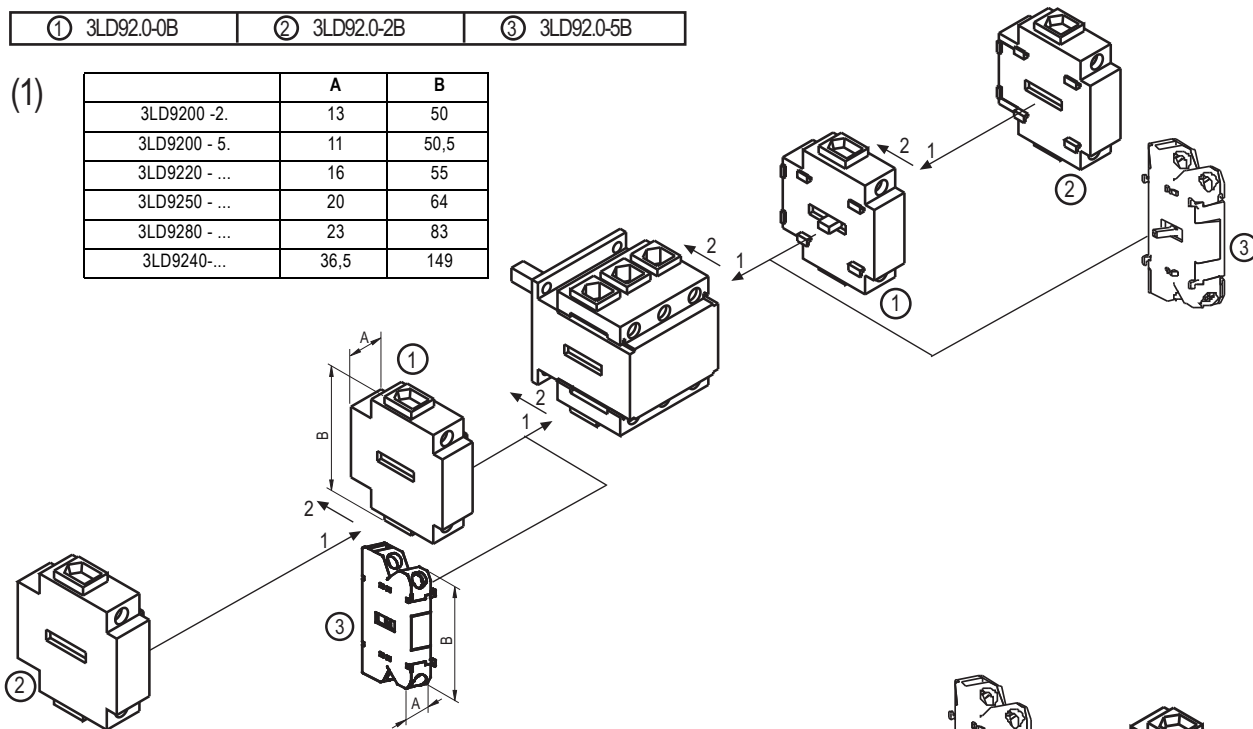

① 3LD92.0-0C	② 3LD92.0-2C	③ 3LD92.0-5C
--------------	--------------	--------------

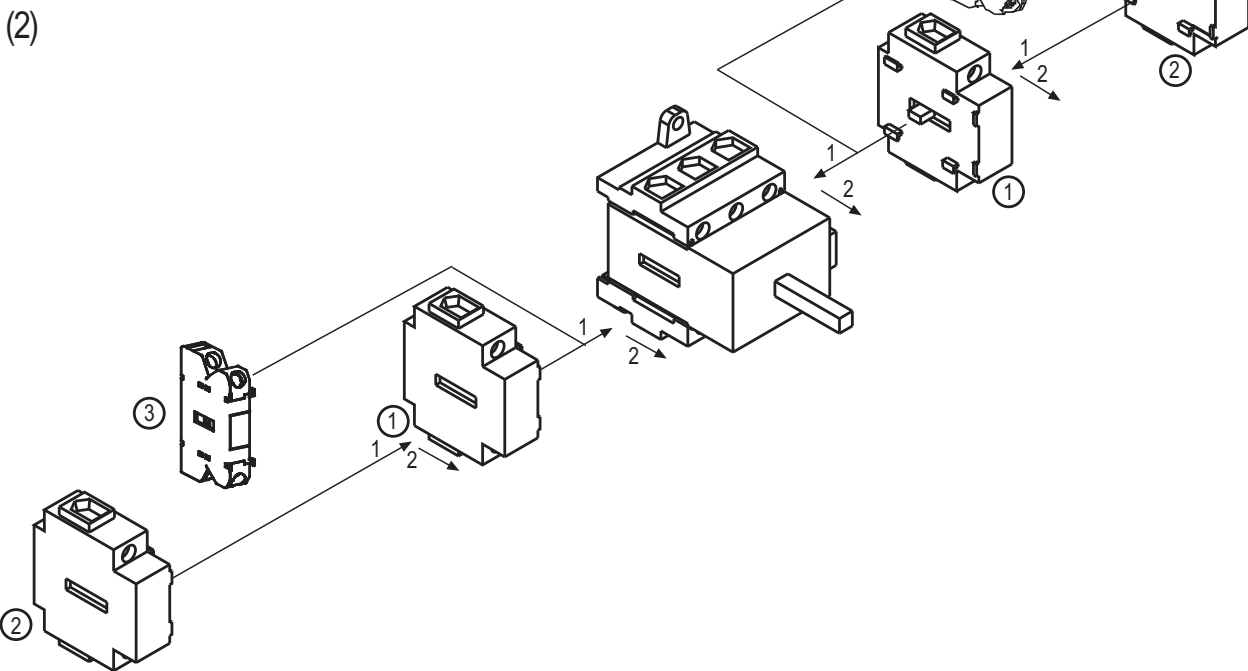

Deutsch

Montage von Zusatzelementen

Schritt	Beschreibung
1	Schalter ausschalten und spannungsfrei schalten
2	Zusatzelemente (Bsp.: Schutzleiter-, Neutralleiterklemme) in die Führung an der linken bzw. rechten Schalterseite stecken und bis zum Anschlag nach vorn schieben (siehe Bilder 1 und 2)
3	Es kann je ein Zusatzelement links und rechts montiert werden. An den schaltbaren Neutralleiter kann noch eine Erdungsklemme (PE) oder ein nicht schaltender Neutralleiter (N) angebaut werden.

Demontage von Zusatzelementen

ACHTUNG

Den Haupt- und NOT-AUS-Schalter vor Demontage ausschalten und spannungsfrei schalten.
Demontage der Hilfsschalter führt zur Zerstörung des Schalters!

Das eingerastete Zubehör wird demontiert, indem man es entgegen der Montage-richtung schiebt.

Montage der Türkupplung (siehe Bild 3)

Ausreißkraft:

Die Ausreißkraft (= Abziehen von der Welle oder Zerstörung des Antriebes) bei verriegelten Antrieben ist ≥ 600 N bei Zug direkt am Antrieb in Richtung der Welle.

Tür-Scharnierabstand:

Der Tür-Scharnierabstand ist ≥ 100 mm.

English

Mounting of additional elements

Step	Description
1	Turn off switch and remove voltage
2	Place additional elements (e.g.: protective earth conductor terminals and neutral conductor terminals) in the slot on the left or right-hand side of the switch and push forward until it clicks) (see Figures 1 and 2)
3	One additional element can be mounted on both the left and the right-hand side. An additional earthing terminal (positive earth) or a non-switchable neutral conductor (N) can be connected to the switchable neutral conductor.

Removing of additional elements

NOTICE

Before removing the Main and EMERGENCY OFF switch turn it off and remove voltage.
Removing of auxiliary switches destroys the auxiliary switch.

The mounted accessories are removed by sliding them in the opposite direction to the mounting direction.

Installation of door coupling (See figure 3)

Pull-out strength:

The Pull-out strength (= being pulled off the shaft or destruction of the mechanism) of locked mechanisms is ≥ 600 N with pulling force exerted directly on the mechanism in the direction of the shaft.

Door hinge spacing:

The door hinge spacing is ≥ 100 mm.

Français

Montage d'éléments supplémentaires

Etape	Description
1	Fermer l'interrupteur et le mettre hors tension
2	Connecter les éléments supplémentaires (ex. bornes de conducteur de protection et de conducteur neutre) sur le guidage à gauche ou à droite de l'interrupteur et les pousser en butée (voir figures 1 et 2).
3	A gauche comme à droite, il est possible de raccorder un élément supplémentaire. On peut raccorder au conducteur neutre commutable une borne de terre (PE) ou un conducteur neutre non commutant (N).

Démontage d'éléments supplémentaires

IMPORTANT

Avant de procéder au démontage, fermer l'interrupteur principal et d'ARRÊT D'URGENCE et le mettre hors tension. Le démontage des blocs de contacts auxiliaires entraîne leur destruction !

Les accessoires fixes sont démontés en les poussant dans le sens contraire à celui du montage.

Montage du couplage de porte (voir figure 3)

Force d'arrachement:

La force d'arrachement (= retrait de l'arbre ou destruction de la commande) des commandes verrouillées est de ≥ 600 N si l'on tire directement sur la commande dans la direction de l'arbre.

Distance entre les charnières de la porte:

La distance entre les charnières est de ≥ 100 mm.

Español

Montaje de elementos adicionales

Fase	Descripción
1	Desactivar el interruptor y desconectar la tensión
2	Insertar los elementos adicionales (p. ej.: borne de conductor protector o de conductor neutro) en la guía al lado izquierdo o derecho del interruptor y empujar hacia adelante hasta el tope (ver figuras 1 y 2)
3	Se puede montar un elemento adicional a ambos lados (izquierdo y derecho). El conductor neutro conmutable puede ser conectado con un borne de tierra (PE) o con un conductor neutro sin conmutación (N).

Desmontaje de elementos adicionales

ATENCIÓN

Antes del desmontaje se deben desactivar y desconectar de la tensión el interruptor principal y el interruptor de parada de emergencia.
¡El desmontaje de los interruptores auxiliares los destruye!

Los accesorios enclavados se desmontan empujando en sentido contrario al sentido de montaje.

Montaje del acoplamiento de puerta (ver figura 3)

Fuerza de arrancamiento:

La fuerza de arrancamiento (= extracción del eje o destrucción del accionamiento) en accionamientos enclavados es ≥ 600 N en caso de tracción directa sobre el accionamiento en sentido del eje.

Distancia bisagra de puerta:

La distancia de la bisagra de puerta es ≥ 100 mm.

Italiano

Montaggio degli elementi aggiuntivi

Passo	Descrizione
1	Disattivare l'interruttore e togliere la tensione
2	Inserire gli elementi aggiuntivi (es.: morsetto del conduttore di protezione, morsetto del conduttore neutro) nella guida sinistra o destra a lato dell'interruttore e spingerli in avanti fino a bloccarli in posizione (vedi figure 1 e 2)
3	È possibile montare un elemento aggiuntivo a sinistra e uno a destra. Sul conduttore neutro innestabile è possibile montare inoltre un morsetto di messa a terra (PE) o un conduttore neutro lineare (N).

Smontaggio degli elementi aggiuntivi

ATTENZIONE

Prima di smontare l'interruttore principale e di arresto di emergenza, disattivarlo e togliere la tensione.
Lo smontaggio dei contatti ausiliari causa danni irreparabili agli stessi.

Per smontare l'accessorio innestato, spingerlo nella direzione opposta a quella di montaggio.

Montaggio del giunto della porta (vedi figura 3)

Forza di strappo:

La forza di strappo (= estrazione dall'albero o danneggiamento dell'azionamento) in azionamenti bloccati è pari a ≥ 600 N se la forza viene applicata direttamente sull'azionamento in direzione dell'albero.

Distancia porta - cerniera:

La distanza tra la porta e la cerniera è pari a ≥ 100 mm.

Português

Montagem de elementos adicionais

Passo	Descrição
1	Desligar a chave e desativar a tensão
2	Inserir os elementos adicionais (p.ex.: borne do condutor de proteção, borne do condutor neutro) na guia no lado esquerdo ou direito da chave e empurrar para frente até o encosto (ver as figuras 1 e 2)
3	Pode ser montado respectivamente um elemento adicional à esquerda e à direita. No condutor neutro comutável ainda é possível instalar mais um borne terra (PE) ou um condutor neutro não-comutável (N).

Desmontagem de elementos adicionais

ATENÇÃO

Antes da desmontagem, desligar e desconectar da tensão a chave geral e a chave de DESLIGAMENTO DE EMERGÊNCIA.
A desmontagem das chaves auxiliares causa a destruição das chaves auxiliares!

O acessório encaixado é desmontado, empurrando-o em sentido contrário da montagem.

Montagem do acoplamento de porta (ver a figura 3)

Força de arrancamento:

A força de arrancamento (= remoção do eixo ou destruição do mecanismo) com mecanismos travados é ≥ 600 N em tração direta no mecanismo no sentido do eixo.

Distância da dobradiça de porta:

A distância da da dobradiça de porta é ≥ 100 mm.

Türkçe

İlave elementlerin montajı

Adım	Tanım
1	Şalteri kapatınız ve gerilimsiz hale getiriniz.
2	İlave elementleri (örn.: topraklama ve nötr iletken kısıkları) sol veya sağ şalter tarafındaki yere sokunuz ve dayanana kadar öne itiniz (Bkz. Resimler 1 ve 2)
3	Sol ve sağ tarafa birer ilave element monte edilebilmektedir. Devreye sokulabilen nötr iletken bir topraklama kısıkağı (PE) veya bir devreye sokulmayan nötr iletken (N) ilave edilebilir.

İlave elementlerin sökülmesi

DİKKAT

Ana ve ACİL KAPAMA şalterini sökmeye önce kapatınız ve gerilimsiz hale getiriniz. Yardımcı şalterin sökülmesi, yardımcı şalterin tahribatına yol açar!

Montelenmiş aksesuar, monte yönünün tersine itilmek suretiyle sökülür.

Kapı kuplaj montajı (Bkz. Resim 3)

Çekme kuvveti:

Kilitli tahrik tertibatlarında çekme kuvveti (milden çekmek veya tahrip etme) doğrudan tahrik tertibatında mil yönünde çekişte ≥ 600 N'dir.

Kapı-Menteşe mesafesi:

Kapı-Menteşe mesafesi, ≥ 100 mm'dir.

Русский

Монтаж дополнительных элементов

Шаг	Описание
1	Выключатель отключить и прекратить подачу напряжения
2	Дополнительные элементы (напр.: клемма защитного провода, клемма нулевого провода) вставить в направляющую на левой или соответствующе правой стороне выключателя и продвинуть до конца вперёд (смотри рис. 1 и 2).
3	Справа и слева можно монтировать по одному дополнительному элементу. На выключаемом нулевом проводе возможен монтаж дополнительной клеммы заземления (PE) или невключаемого нулевого провода (N).

Демонтаж дополнительных элементов

ВНИМАНИЕ

Перед демонтажем выключить главный и АВАРИЙНЫЙ выключатели и отключить напряжение. Демонтаж дополнительных выключателей приводит к их разрушению!

Демонтаж зафиксированных комплектующих деталей осуществляется путём их перемещения в сторону, противоположную направлению монтажа.

Монтаж дверной сцепки (смотри рис.3)

Сила вырывания:

Сила вырывания (= снятие вала или разрушение привода) при заблокированных приводах равна ≥ 600 Н в случае, если тянуть непосредственно у привода в направлении вала.

Расстояние между шарнирами двери:

Расстояние между шарнирами двери составляет ≥ 100 мм.

中文

附加部件的安装

步骤	描述
1	断开开关并使其处于零电压状态
2	附加部件 (例如: 接地安全引线端子, 零线端子) 插入开关左侧或右侧的插孔直到销挡处再向前推 (参见图 1 和 2)
3	可在左侧和右侧各安装一个附加部件。在可通断的零线处还可加装一个接地端子 (PE) 或一个不接通零线 (N)。

附加部件的拆卸

注意

在拆卸前必须先关闭主开关和急停开关并切断电源。

拆卸辅助开关会导致辅助开关损坏!

往与安装方向相反的方向推可通过卡槽安装的附件拆卸下来。

门耦合的安装 (参见图 3)

拉拔强度:

当拉力直接作用于驱动装置机轴方向时, 门闭锁驱动时的拉拔强度 (= 自机轴脱出或驱动装置损坏) 大于或等于 ≥ 600 N。

门铰链距离:

门铰链距离为大于或等于 ≥ 100 mm。

Bild 3 / Figure 3 / Figure 3 /
Figura 3 / Figura 3 / Figura 3 /
Resim 3 / рис. 3 / 参见图 3

