

# PROTOCOL CONVERTER RS232 ↔ RS485/422 Half/Full Duplex S107P

## *GENERAL SPECIFICATION*

- Communications Mode : 2 wire Half Duplex , 4 wire Full Duplex, point to point or multidrop
- Baud Rates : 9600 , 19200 , 38400 , 57600 , 115200 baud selectable
- Flow Control : Automatic or RTS line
- Indication : 4 LEDs, Power ON, Rx, Tx and RTS active
- Power Supply : 9 ÷ 12 Vdc 100mA (Plug top style DC power supply included).
- Transmission Distance : up to 1200m.
- Isolation : 1000Vac between RS232 & RS485, 1000Vac between supply & RS485
- RS232 Connection : Integral 750mm cable with DB9 female connector
- RS485 Connection : 5 way plug in screw terminal block
- Power Connection : 2 way plug in screw terminal block

## *TECHNICAL SPECIFICATION*

Power Supply:	9 Vdc – 1W
Communications Ports:	Serial RS232, serial RS485/422
Operating Conditions	0..55°C, 30% to 90% RH @ 40°C (non condensing)
Enclosure:	Beige ABS (Self Extinguishing)
Dimensions & Weight:	Approx 100 x 50 x 24 mm, 90g
Standards	The instrument conforms to the following standards: EN50081-2 (electromagnetic emissions, industrial) EN50082-2 (electromagnetic immunity, industrial) EN61010-1 (safety)



## *INSTALLATION*

To ensure correct operation of the S107P converter, please observe the following guidelines:

- Always use screened, twisted pair cable – particularly in electrically noisy environments or when using long cable runs. (See the SERIAL INTERFACE section)
- Separate RS232/422/485 cabling from power cables.
- Set the Dip Switches and make all serial connections BEFORE applying power to the converter
- The converter may be used at Baud rates lower than 9,600 – but the RTS line MUST be used

## *TROUBLESHOOTING*

If the S107P does not appear to function as expected, please refer to the troubleshooting chart below :

Symptom	Solution
The green "POWER" LED is not lit	Check that the polarity of the DC supply and that 230V mains is available to the adapter.
The red "Rx" LED always lit.	Try reversing the RS485 "A" and "B" connections
Data is corrupt	Check that the converter is set at the same Baud rate as the Computer and for the same flow control (RTS or Auto)

# CONNECTION DIAGRAM

## HALF DUPLEX (2 wire RS485)

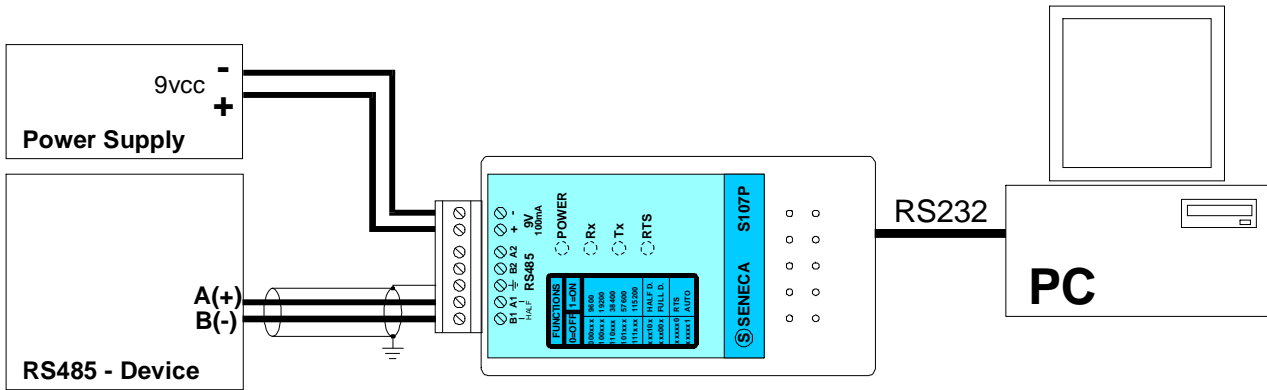

## FULL DUPLEX (4 wire RS485, RS422)

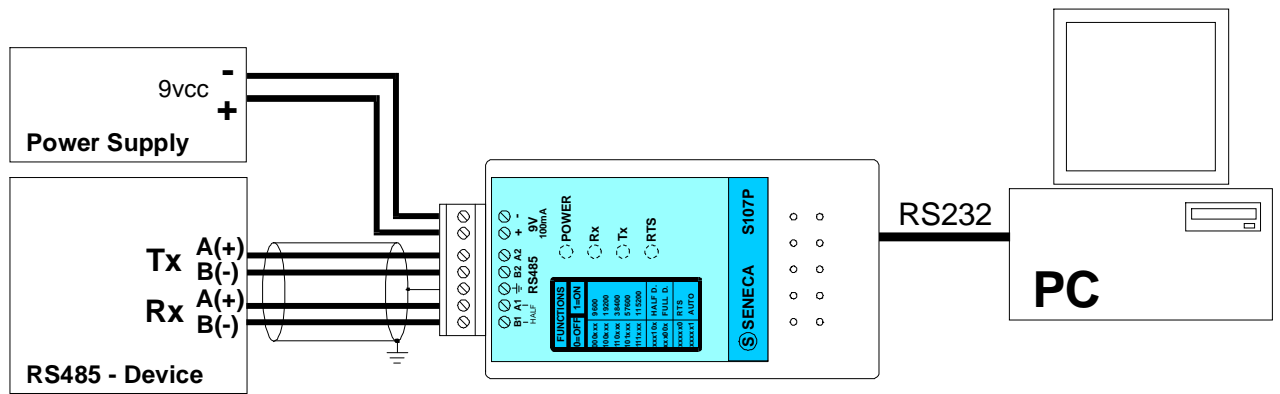

# DIP-SWITCH SETTINGS

## Baud Rate Setting:



The dip switches used to select the speed and mode of the converter are situated next to the RS232 connection cable

**NOTE :** It is only necessary to set the Baud Rate if you are using the AUTO setting

## Half / Full Duplex setting:



## Transmit / Receive Switching:



**NOTE :** RTS/Auto only applicable in HALF DUPLEX mode

The RS485 serial interface is based on balanced line differential with a typical impedance of 120 Ohms. The maximum distance is not actually defined as it depends on the speed of communication, the signal to noise ration and the quality of cable used.

Generally, 1200m is taken to be the maximum distance that reliable communication can be guaranteed. For distances of up to a few meters in a low noise environment, almost any cable can be used. For cable lengths up to about 100m almost any screened twisted pair cable will suffice. Above this, the use cables that meet the RS485 standard such as CEAM CPR 6003 or BELDEN 9841.

The recommended cabling is layout is “daisy chain” although short “spurs” up to about 2m can be tolerated. The “star” topology is not recommended and should be avoided. The communications line should be terminated by switching the line termination dip switch ON (if using the Seneca Z-PC line modules) on the last module, or by putting a 120Ohm resistor across the two lines at the end of the cable.

The screen should be connected to the **GND** terminals where they are available and the screen should also be connected to Earth in at least 1 place, via a 10 nF capacitor if necessary

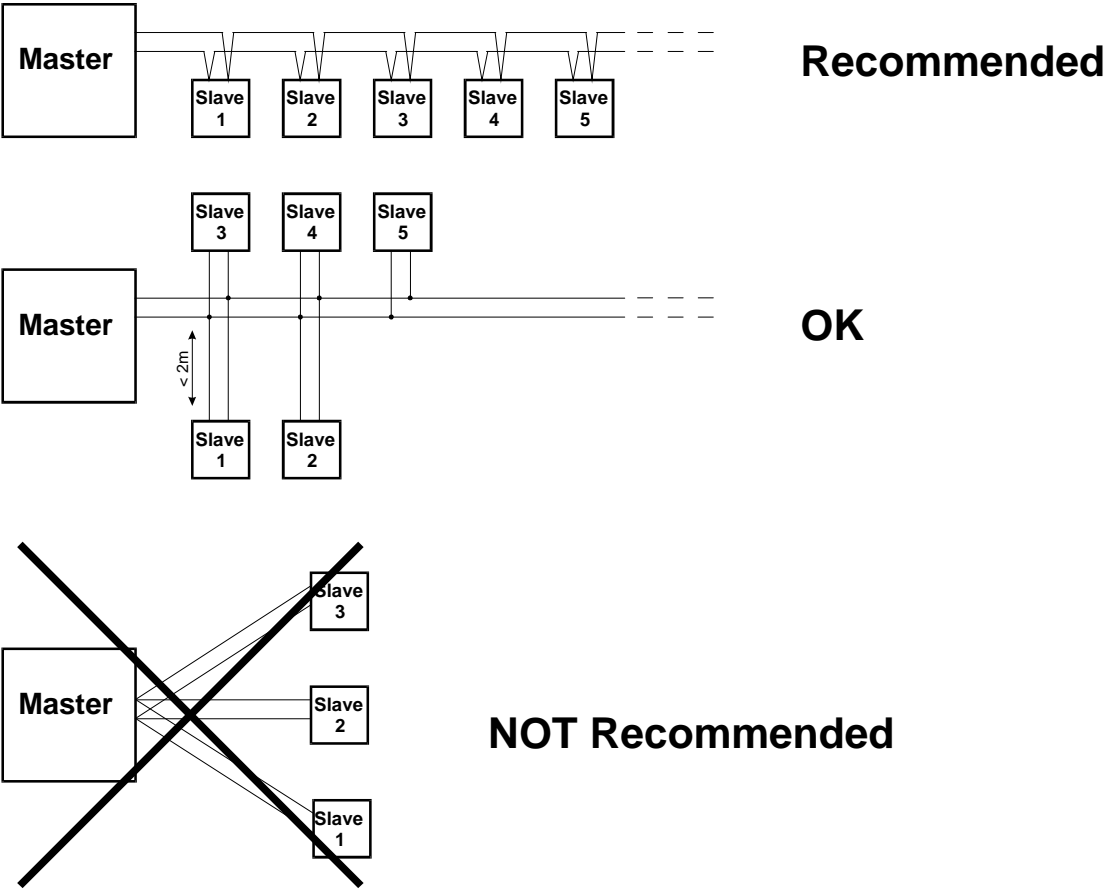

**CONNECTIONS**

**RS232 Connections:**

Pin	Function
2	RXD
3	TXD
5	GND
7	RTS

**RS485 Connections**

Pin	Function
1	B(-) RS485 (HALF D or Tx in FULL D.)
2	A(+) RS485 (HALF D or Tx in FULL D.)
3	GROUND
4	B(-) RS485 ( Rx in FULL D.)
5	A(+) RS485 ( Rx in FULL D.)

## FRONT PANEL INDICATION

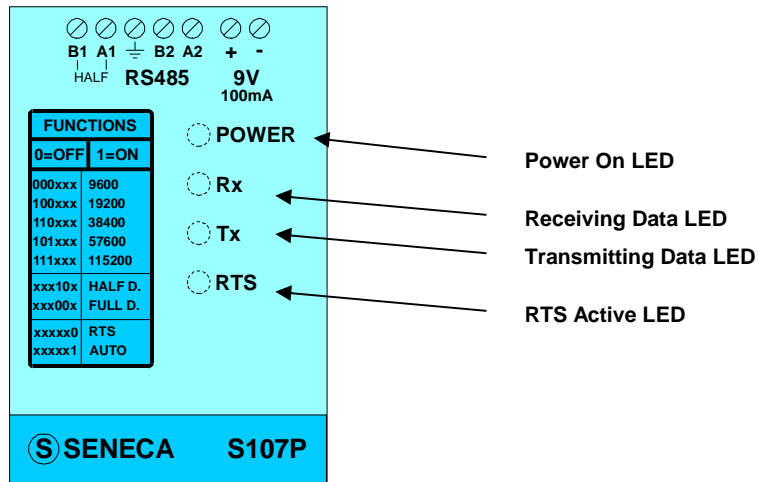

## DIMENSIONS

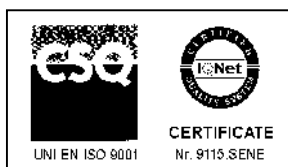
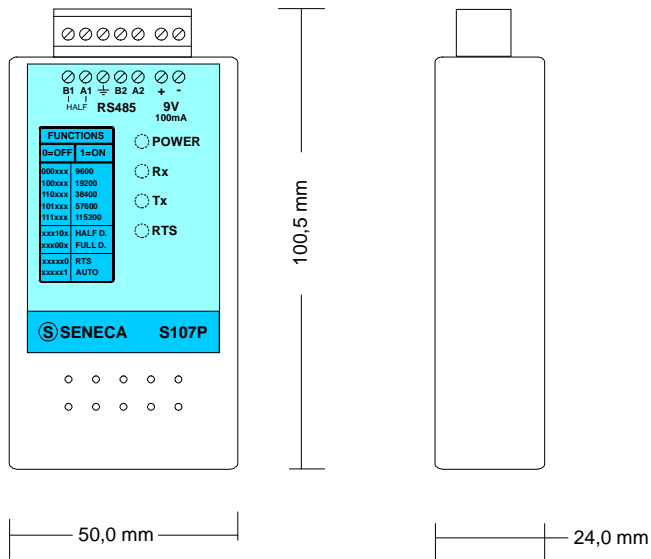

**SENECA s.r.l.**  
 Via Austria, 26 - 35127  
 35127 - PADOVA - ITALY  
 Tel. +39.049.8705355 - 8705359  
 Fax +39.049.8706287  
 e-mail: [info@seneca.it](mailto:info@seneca.it)  
[www.seneca.it](http://www.seneca.it)